

## 75mm (3") Wire Rope Cutter Cutters & Grinders.

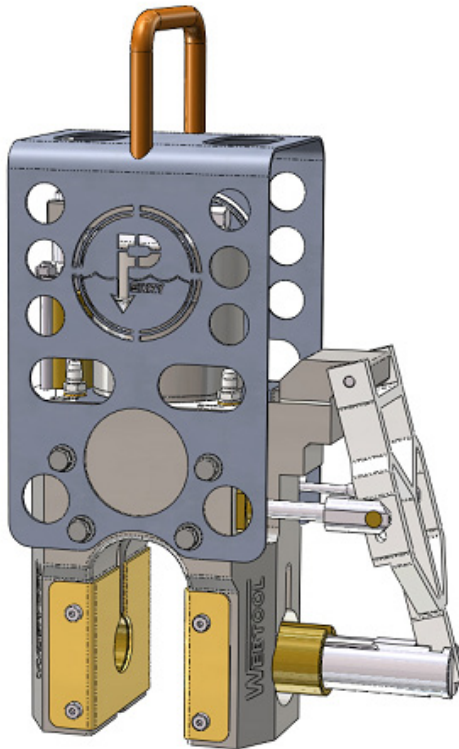

### DESCRIPTION

The 75mm Wire rope cutter RCV75HD is suitable for cutting grades up to 1960N/mm<sup>2</sup> and up to 75mm in diameter. Utilising a fully retractable anvil the cutter can be placed over continuous lengths of wire ropes for simplified cutting operations. The cutting cylinder is supplied complete with pressure intensifier from Webtool. This tool is suitable for local or remote operations in sub-sea environments (i.e. on an ROV) and due to its high quality construction requires little or no maintenance throughout its operational life. Replacing the anvil or cutting blade is a simple task and spares kits comprising both components and all seals are available at any time. All spares provided are genuine Webtool components. The tool is supplied with ROV handle and separate cutter/anvil connection hoses.

### FEATURES

- Cuts up to 75mm 1960N/mm<sup>2</sup> Wire
- Supplied with ROV handle
- Hydraulic Retract
- Supplied in offshore suitable transit case.

# 75mm (3") Wire Rope Cutter

## Cutters & Grinders.

### SPECIFICATIONS

Max Operating Pressure	210Bar (3,000PSI)
Max Wire Diameter	75mm
Max wire strength	1960N/mm <sup>2</sup>

### WHAT'S IN THE BOX

RCV75HD Cutter  
ROV Handle  
Supply and return hoses.  
Operations & Maintenance Manual.

### PART NUMBERS & OPTIONS

A036-026-150	75mm (3") Wire Rope Cutter
A036-026-150/SK	Basic Spares Kit

