

# COILED TUBING PRESSURE CONTROL

 +1.877.682.5189

 [f-e-t.com/ctpc](https://f-e-t.com/ctpc)

 [intervention.sales@f-e-t.com](mailto:intervention.sales@f-e-t.com)



# About Us

In 2008 Vanoil, which was a trusted manufacturer for over 30 years, joined Forum Energy Technologies. As an API licensed, top tier producer of coiled tubing blowout preventers and supporting equipment, Forum’s Pressure Control Equipment is utilized worldwide by both major and independent service companies.

Our experienced management team and employees are dedicated to solving our customers’ problems. We invest in long term relationships and cooperate on product development with our clients. Built for ease of operation, serviceability, and maximum durability – Forum’s Vanoil products are manufactured in Broussard, LA USA to specifications under ISO 9001-2015, API 6A and API Q1.

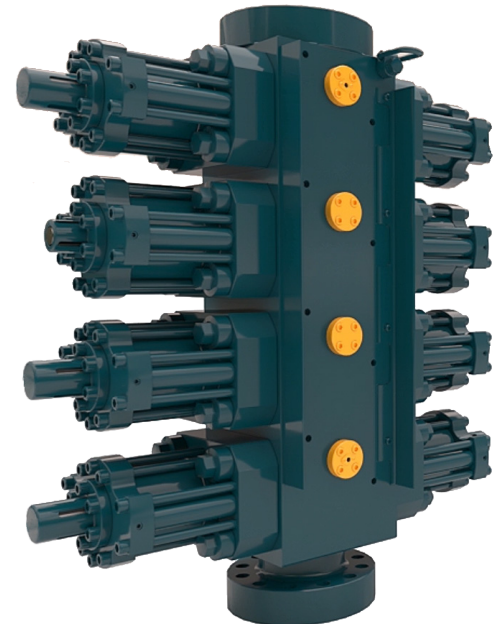

- Best in class aftermarket support. Forum’s focus is taking care of the customer after the sale through responsive and local service / recertification, strategic spares placement, and technician training.
- Compact Designs. Industry’s lightest and smallest 5-15 KSI equipment and dual-door strippers.
- Serviceability Features. Less parts. Accessible rams. Field-replaceable brass available for all strippers.
- Customizability. All Forum PCE can be customized to support special projects. Our experienced and extensive engineering team stands ready to support your needs.

## Equipment Types

Forum offers all major components of the CT pressure control stack in a variety of working pressures, sizes, internal configurations, and connection types.

- Blow-Out Preventers (Quad, Dual, and Single Ram Bore)
- Stripper/Packers (Single and Dual Packer Designs)
- Lubricators
- Adapters/Crossovers
- Specialty Components/subs
- Rotating Joints/Swivels

## Specifications

Standard equipment is available to meet most requirements. The product line continues to expand to meet the emerging needs of the market.

- Working Pressures: 5 - 10 - 15 KSI
- Standard Bore Sizes: 3 1/16” 4 1/16” 5 1/8” 7 1/16”
- String Sizes: 3/8” to 3 1/4” Coiled Tubing
- Operating Temp: STD -29°C to 121°C (-20 to 250°F) or LOW -45°C to 82°C (-50 to 180°F)
- Service: H2S
- Operating Pressure: 3000 PSI (Max) Hydraulic

# Stripper/Packers

## General Specifications

- Service: H<sub>2</sub>S
- Standard Operating Temperatures: -29°C to 121°C (-20°F to 250°F)
- Low Operating Temperatures: -45°C to 82°C (-50°F to 180°F)
- Various Flanged Connections and Quick Union options available
- Top and Bottom Brass can be exchanged through the window on most models

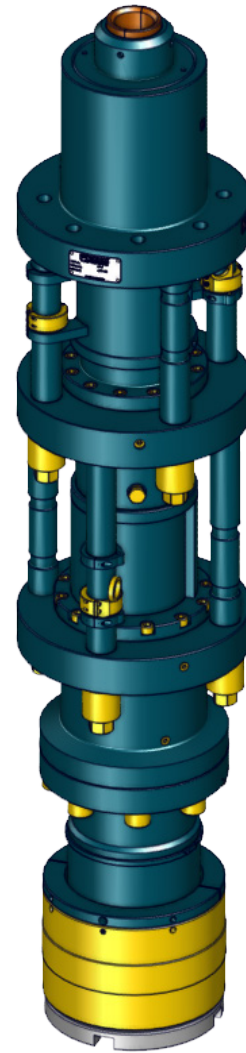

Type	Pressure	Bore Size	Connections	Max Coil	Weight*	Dimensions*
Dual	15 KSI	4 1/16"	BX Flange or Unions 3 1/16" - 5 1/8"	2 7/8"	1,750 lbs.	72" x 17"
Single	15 KSI	4 1/16"		2 7/8"	1,035 lbs.	43" x 17"
Dual	10 KSI	4 1/16"		2 7/8"	1,750 lbs.	72" x 17"
Single	10 KSI	4 1/16"		2 7/8"	1,035 lbs.	43" x 17"
Single	10 KSI	3 1/16"		2"	292 lbs.	34" x 12"

\*Varies with connection selected.

# 10 KSI BOPs

## General Specifications

- Service: H2S
- MWP: 10,000 PSI
- Standard Operating Temperatures: -29°C to 121°C (-20°F to 250°F)
- Low Operating Temperatures: -45°C to 82°C (-50°F to 180°F)
- Ram Types: Blind, Shear, Slip, Pipe, Shear-Seal, Slip-Seal

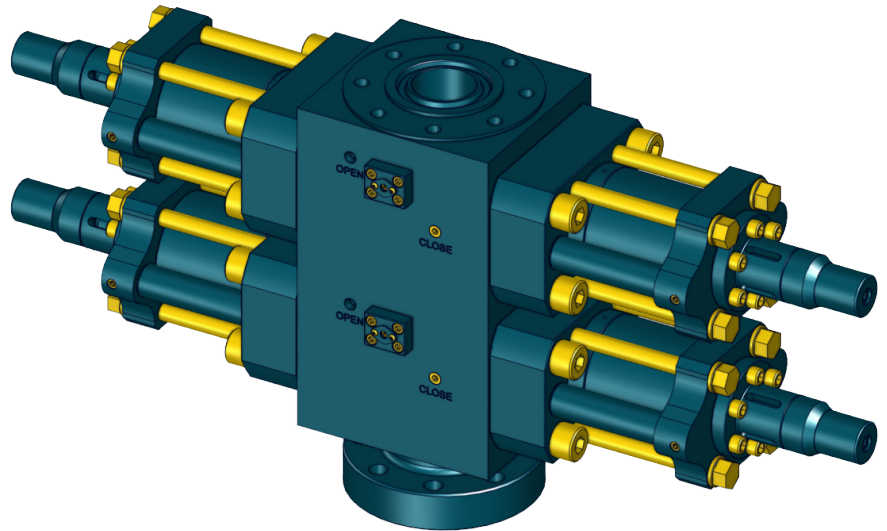

Type	Size	Weight	Dimensions	Max Coil	Bore Size	Flanged Connections	Part Number
QUAD	5-1/8	5,519 lbs	57 x 59 x 16	3 1/4	5.12	BX-169	P506QBX0
QUAD	4-1/16	3,800 lbs	49 x 52 x 14	2 3/8	4.06	BX-155	P406QBX0C
QUAD	3-1/16	1,400 lbs	34 x 34 x 11	2	3.06	BX-154	P306QB00A
DUAL	5-1/8	2,994 lbs	33 x 69 x 16	2 7/8	5.12	BX-169	P506DBX0
DUAL	4-1/16	2,200 lbs	28 x 60 x 14	2 3/8	4.06	BX-155	P406DBX0C
DUAL	3-1/16	1,125 lbs	22 x 42 x 11	1 3/4	3.06	BX-154	P306DCB0
SINGLE	5-1/8	1,606 lbs	20 x 69 x 16	2 7/8	5.12	BX-169	P506SBX10
SINGLE	4-1/16	1,362 lbs	18 x 60 x 14	2 3/8	4.06	BX-155	P406SBX10
SINGLE	3-1/16	564 lbs	18 x 42 x 11	1 3/4	3.06	BX-154	1089497



# 15 KSI BOPs

## General Specifications

- Service: H2S
- MWP: 15,000 PSI
- Standard Operating Temperatures: -29°C to 121°C (-20°F to 250°F)
- Low Operating Temperatures: -45°C to 82°C (-50°F to 180°F)
- Ram Types: Blind, Shear, Slip, Pipe, Shear-Seal, Slip-Seal

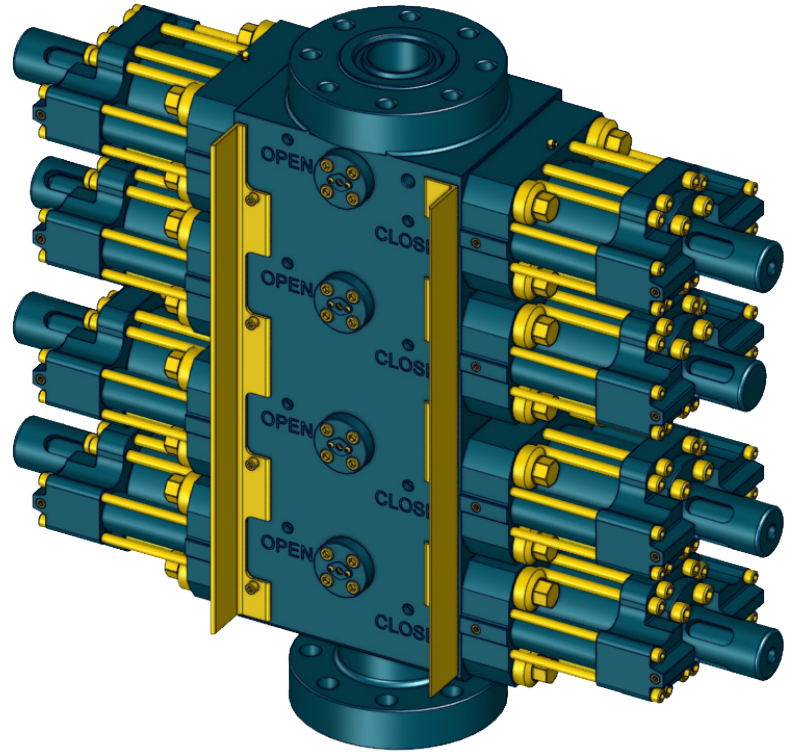

Type	Size	Weight	Dimensions	Max Coil	Bore Size	Flanged Connections	Part Number
QUAD	5-1/8	6,526 lbs	64 x 57 x 17	2 7/8	5.12	BX-169	1126911
QUAD	4-1/16	4,438 lbs	48 x 56 x 15	2 3/8	4.06	BX-155	1025784
DUAL	5-1/8	3,923 lbs	38 x 72 x 17	2 7/8	5.12	BX-169	1114963
DUAL	4-1/16	2,384 lbs	28 x 63 x 15	2 3/8	4.06	BX-155	1027175
SINGLE	5-1/8	2,330 lbs	32 x 66 x 17	2 7/8	5.12	BX-169	1169134
SINGLE	4-1/16	1,688 lbs	29 x 63 x 15	2 3/8	4.06	BX-155	1044079

# Rotating Joints

## Description

Forum's Coiled Tubing rotating joints / swivels are designed to support your CT pumping operations with a variety of bore sizes, connection types, and shapes, including 90°, 180°, and straightbore. Multi-style seals and a heavy duty bearing design in a hydraulic oil bath ensures a wide pressure sealing range and a long, reliable service life.

## Features

- Roller bearing design to provide longer bearing life
- Oil bath for bearings with oil level check port.
- Advanced packing stack design provides improved seal over a wide range of pressures and temperatures.
- Includes weep port to indicate faulty packing stack.

## General Specifications

- Bore Size/MWP: 1.5" - 2.5" 10,000 PSI to 15,000 PSI
- Service: Standard/H2S
- Standard Operating Temperatures: -29°C to 121°C (-20°F to 250°F)
- Low Operating Temperatures: -45°C to 82°C (-50°F to 180°F)

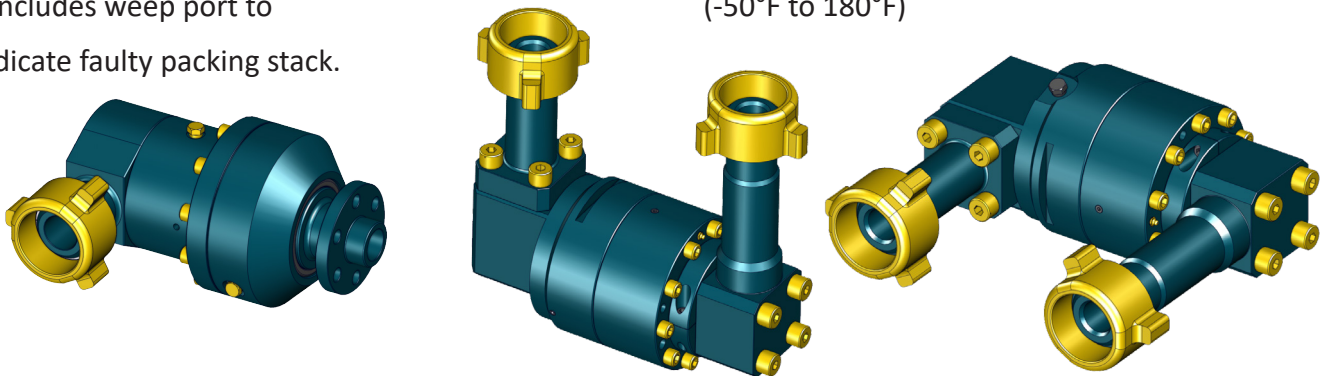

## Lubricators | Spools, Adapters | Crossovers, Flow Tees Crosses, Chemical Injection Subs, Quick Test Subs

## Description

Forum offers a wide selection of pressure control accessories and equipment including lubricators, adapters, flow tees/crosses, and bleed subs. All equipment matches the working pressure, service rating, and end connections consistent with surface pressure control equipment.

## Features

- Lubricators/Risers (Integral or Threaded)
- Adapters/Bleed Subs
- Flow Tees/Crosses

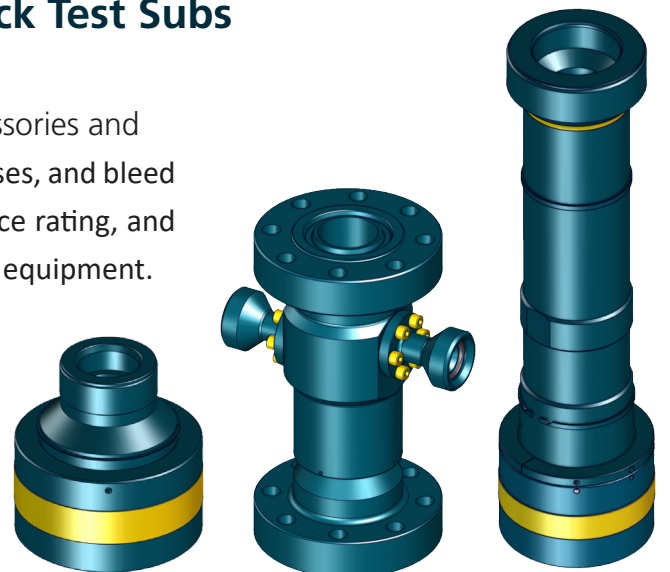

# Aftermarket Support

## Strategic Spares System

From our primary distribution center in Louisiana, USA – Forum positions critical spares globally by leveraging our locations in the Middle East, Asia, and Europe. Where Forum does not have a direct presence, we partner with trusted agents and distributors to ensure equipment owner’s timely access to spare parts.



## Global Service & Recertification Program

Forum stresses the importance of proper maintenance and recertification of our equipment to ensure a long, effective life. Our technicians are standing by to deploy globally when the need arises. For major maintenance and recertification, Forum has partnered with approved vendors in strategic locations across the globe. Recertification provided in such facilities is conducted under direct OEM monitoring and all equipment undergoes an OEM inspection prior to issuance of a Letter of Conformance.

## Customer Training

Forum offers globally deployable training for equipment owner technicians and operators, focusing on basic maintenance and troubleshooting. The programs provide certification to technicians to meet the API “competent person” standard.



## OUR CORE VALUES

### No One Gets Hurt

The safety of our employees and customers is our first priority coupled with a healthy respect for the environment.

### Integrity

In everything we do, in every interaction, both internally and externally, we strive to operate with the utmost integrity and mutual respect.

### Customer Focused

Our products enhance our customer's performance and we listen to their needs and work with them to solve their challenges.

### Good Place To Work

We are committed to creating a workplace that fosters innovation, teamwork and pride. Every team member is integral to our success and is treated equally and fairly.



#### **Forum Energy Technologies**

10344 Sam Houston Park Drive, Suite 300  
Houston, TX 77064



+1 877-682-5189



[f-e-t.com/ctpc](http://f-e-t.com/ctpc)



[intervention.sales@f-e-t.com](mailto:intervention.sales@f-e-t.com)