

## DuraClamp Single-Bolt Connector

Pressure Pumping solutions built for real-world operations.

Engineered to eliminate the need for hammer unions, the **FET DuraClamp Single-Bolt Connector** provides the fastest and safest 15,000 PSI rated iron connector available in the industry.

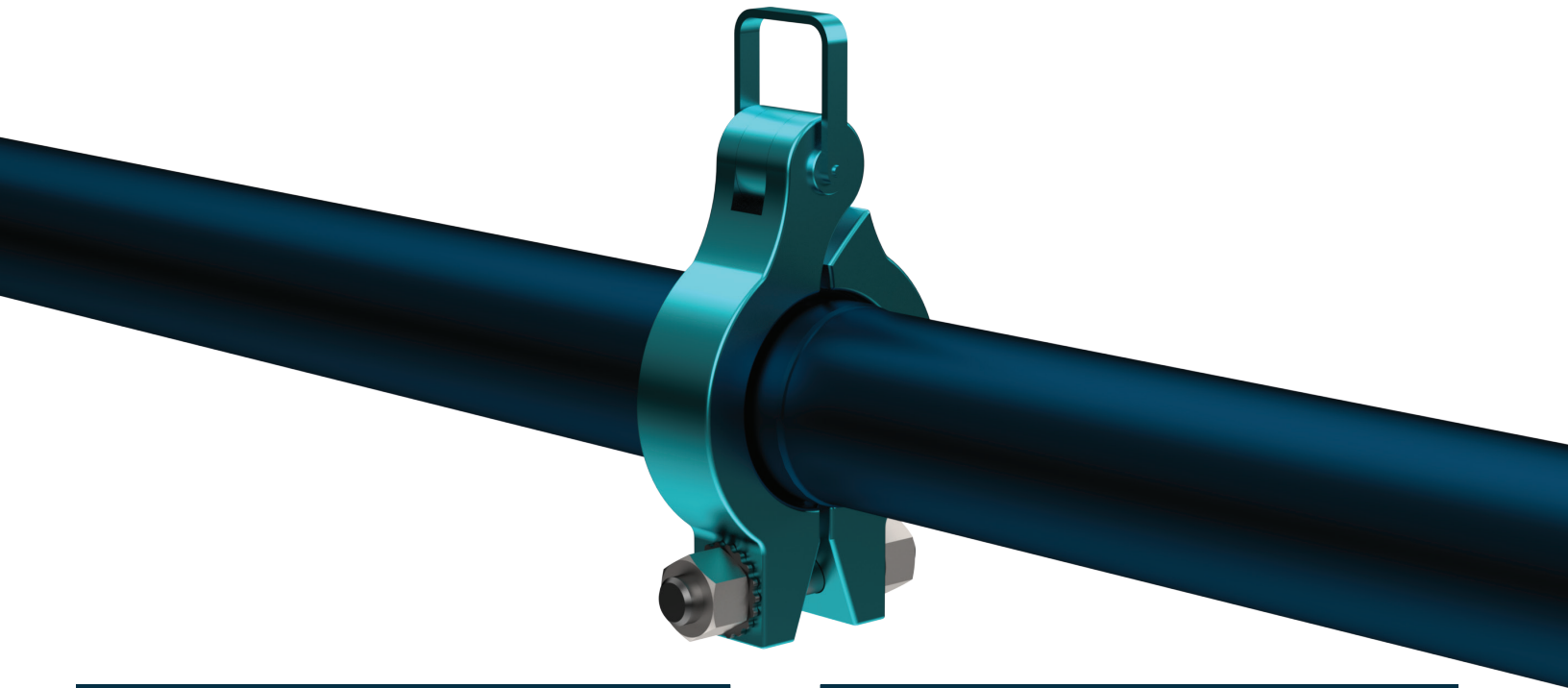

### Design Features & Benefits

- Safer and easier installation than any other high-pressure iron connector in the industry
- Significantly faster make up and break down processes minimize maintenance downtime
- Forged construction provides superior integrity
- 360° orientation allows the clamp to be arranged around obstacles
- Up to 80% lighter and significantly smaller than a comparable ANSI or API flange
- 75% less components to manage
- Greater vibration fatigue resistance compared to traditional hammer union alternatives.

### Technical Specifications

- Weight: 43 Lbs.
- Max Pressure Rating: 15,000 PSI
- Torque Requirement: 1,200 LB-FT
- Design Codes: Designed in compliance to ASME B31.3 and API 6A international codes and standards.

## DuraClamp Single-Bolt Connector



### DuraLock Sealing Interface

- Dual-elastomer design mitigates leaks due to grit and contaminants versus a standard metal-to-metal gasket
- High-strength, corrosion-resistant seal carrier material promotes re-usability which reduces operating costs
- Pressure-energized seals assure joint integrity even at extreme pressures and exposure to aggressive chemicals
- Streamlined flow bore with zero obstruction
- Simplified iron alignment with recessed seal assembly

