

# PBV<sup>®</sup> 44/64 and 54

## FLANGED FLOATING BALL VALVES

 +1 281 637 2000

 [f-e-t.com/PBV](http://f-e-t.com/PBV)

 [ForumVS.PBV@f-e-t.com](mailto:ForumVS.PBV@f-e-t.com)

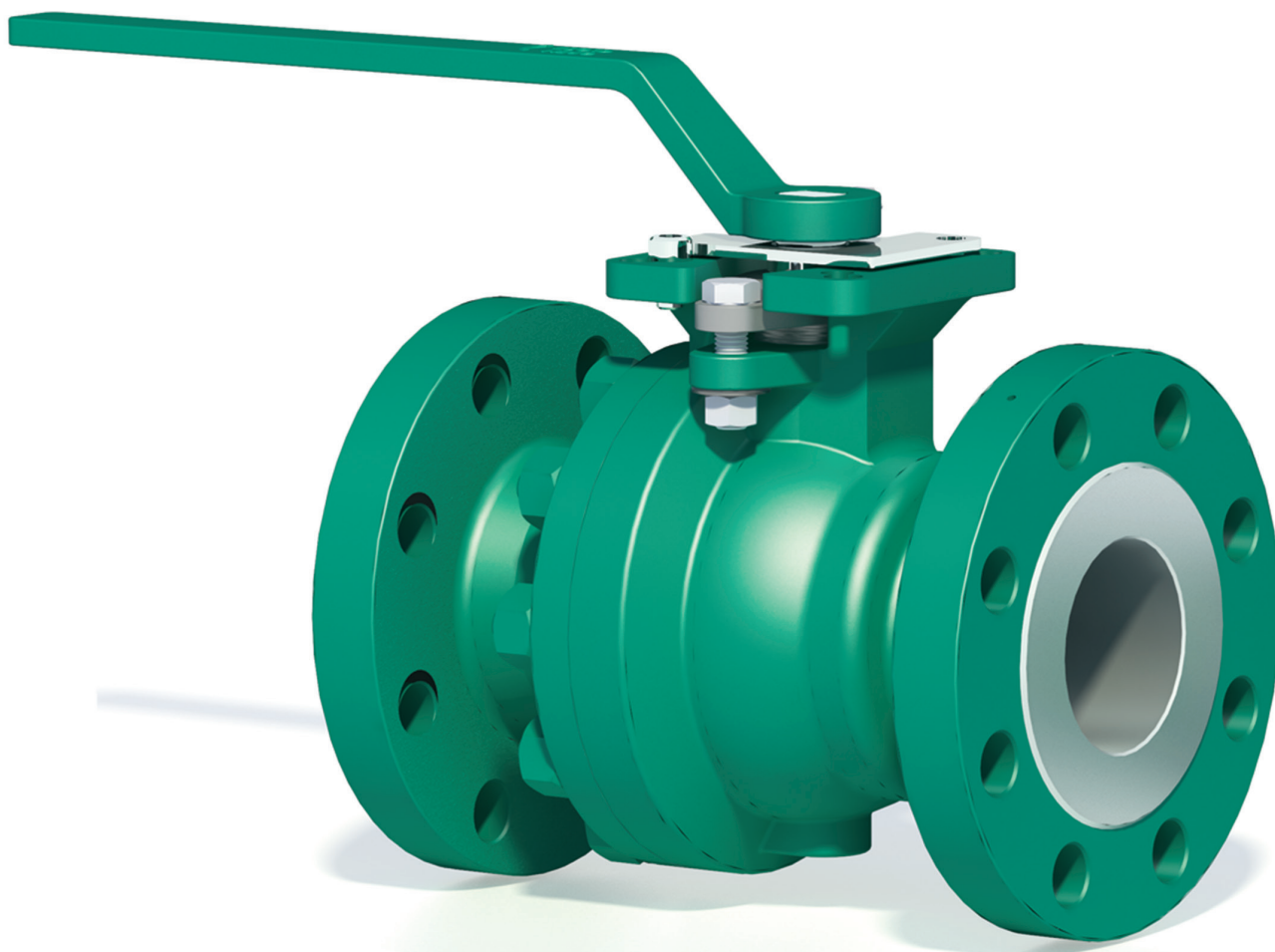

## MANUFACTURER OF QUALITY VALVE PRODUCTS AROUND THE GLOBE

Forum Energy Technologies (FET) is committed to improving our clients’ operational and financial performance by supplying the most comprehensive range of valve products in the industry through our family of trusted valve brands.



## ABOUT FET

### Engineering Expertise

FET uses the latest state-of-the-art engineering software to provide custom design services for any application. Finite element analysis is just one of many Design Verification Tools FET uses to design valves to specific customer requirements.

### CAD & CNC Capabilities

With FET’s fast and efficient workflow, CAD drawings are releasable to the network for manufacturing and purchasing. Computer-generated machine programs can be quickly changed for weld overlays or other processes, resulting in faster deliveries.

### Accurate Inventories

Daily cycle counting and order picking using barcode and automated part delivery systems results in more accurate inventories and faster product delivery.

### Quality Control

All FET Companies manufacture quality products designed and tested to meet the standards of Qualifying Authorities worldwide. Advanced engineering and our Quality Management System ensure that our valve products continue to exceed your expectations for performance.

### Customer Service

FET staffs its Customer Service Department with trained representatives ready to help you with ordering information, technical specifications, and logistics.

## Contents

Design Standards & Specifications .....	3	PBV 44/64 Two-Piece:	
Features.....	4-5	Parts and Materials .....	8
How to Order.....	6	Dimensional Data .....	9-10
Figure Numbers and Product Range.....	6	Mounting and Weights .....	11-12
Ball Valve Stem Torques.....	7	PBV 54 Unibody:	
Flow Coefficients (Cv).....	7	Parts and Materials.....	13
Pressure/Temperature Ratings.....	7	Dimensional Data .....	14
		Mounting and Weights .....	15

*Due to upgrades in industry standards, material innovations, and FET/PBV's constant commitment to product advancement, data presented in this brochure are subject to change. Please contact your PBV sales representative for updated and current drawings and material compliance.*

**Note:** Data contained in this document is for informational purposes and shall not be used for design purposes.

## DESIGN STANDARDS & SPECIFICATIONS

### Certification of Quality and Design

Quality systems are a way of life at PBV. In addition, PBV functions under the requirements of an API Q1 quality program. Our facilities and quality programs are always open to customer audits. PBV maintains active involvement in API, ASME, and MSS standards organizations.

### PBV Quality Procedures

Tests and inspections on every valve are performed throughout production to ensure products meet PBV quality standards. Quality holdpoints include receiving inspection, pressure testing, and final inspection to confirm the performance of all marking, tagging, and processing according to PBV and leading industry standards.

### PBV Floating Ball Valves are designed to meet the following industry standards.

#### **American Petroleum Institute**

- API 608 • Metal Ball Valves — Flanged, Threaded, and Welding Ends
- API 598 • Valve Inspection and Testing
- API 607 • Fire Test for Soft-Seated Ball Valves
- API 641 • Type Testing of Quarter-Turn Valves for Fugitive Emissions
- API Q1 • Specifications for Quality Programs
- API 6FA • Fire Test for Valves\*
- API 6D • Specifications for Pipeline Valves\*

#### **Manufacturers Standardization Society**

- MSS SP-25 • Standard Marking System for Valves
- MSS SP-55 • Quality Standard for Steel Castings for Valves

#### **National Association of Corrosion Engineers**

- NACE MR0175 • Sulfide Stress Cracking Resistant Metallic Materials for Oilfield Equipment
- NACE MR0103 • Metallic Materials Resistant to Sulfide Stress Cracking in Corrosive Petroleum Refining Environments\*

#### **American National Standards**

- ASME/ANSI B16.34 • Valves — Flanged, Threaded, and Welding Ends
- ASME/ANSI B16.10 • Face-to-Face and End-to-End Dimensions on Ferrous Valves
- ASME/ANSI B16.5 • Steel Pipe Flanges and Flanged Fittings

#### **International Standards Organization**

- ISO 9001 • Quality Management Systems — Requirements
- ISO 5211 • Industrial Valves — Part-Turn Actuator Attachments

\* Available upon request

## ENGINEERING EXCELLENCE AT WORK

PBV's floating ball valves are available in various materials and configurations to meet your specific project requirements. Shown here is typical construction.

### PBV 44/64 Two-Piece

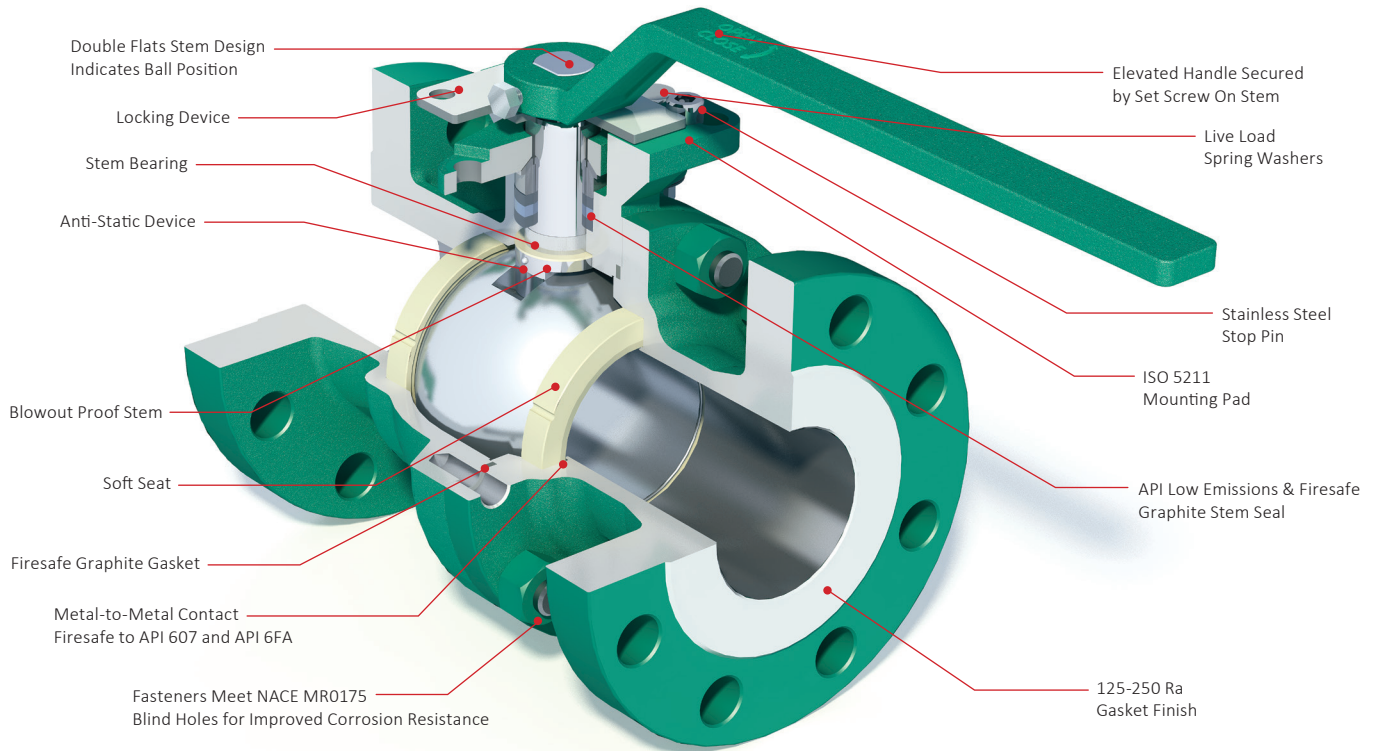

### PBV 54 Unibody

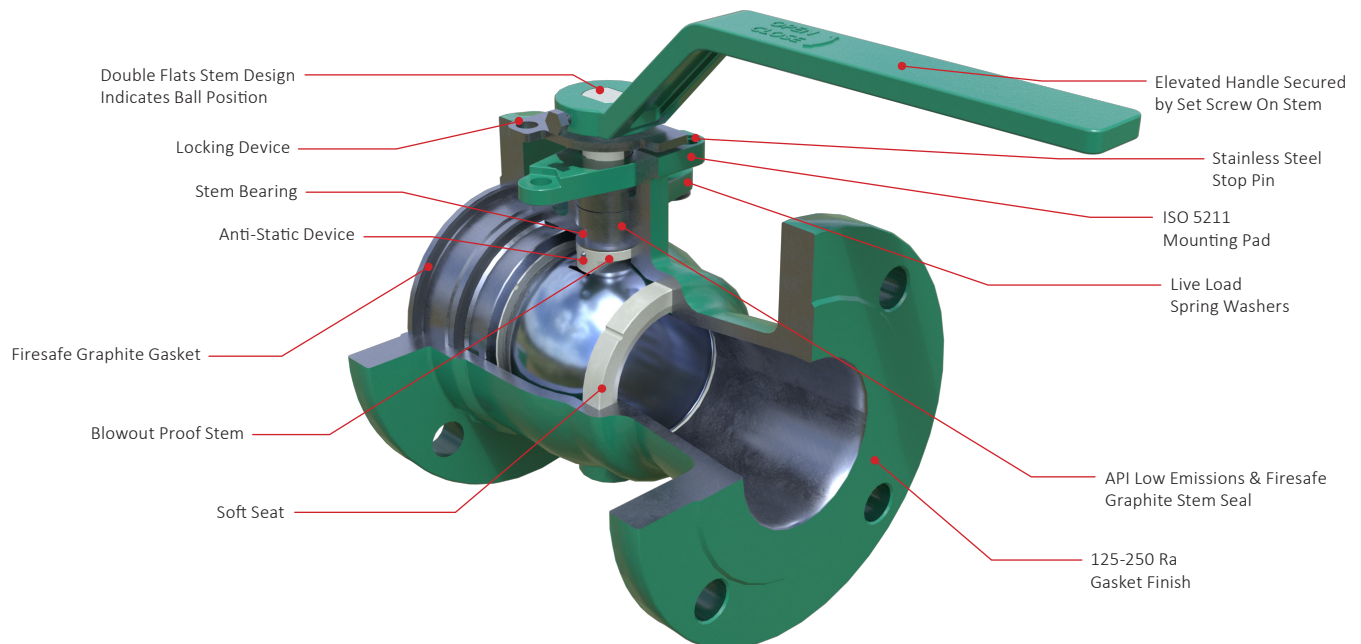

## FEATURES

Standard design features, product line range, material selection, and centrally located operations facilities all combine to make PBV the first choice for floating ball valves. Whether the intended use is in the petrochemical, pharmaceutical, or pulp and paper industries, the PBV floating ball valve designs provide a higher standard of service and value.

Key features, such as the 300 Series Stainless Steel gland, NACE MR0175 bolting, 125-250 Ra flange finish, and API 608 port diameters, enhance the inherent ball valve characteristics of quick quarter-turn operation, bi-directional shut-off capability, ease of automation, and low maintenance design.

### Body and Trim Material

Body material options are ASME grades WCB, LCC, and CF8M, with Stainless Steel trim. Seat and seal options include materials designed to withstand multiple environments and repeated cycling.

### NACE Compliance

All materials used by PBV follow the prequalified materials identified in NACE MR0175/ISO 15156. To ensure compliance, customers must provide application-specific operating conditions. PBV valves are supplied standard with Stainless Steel balls and stems. The material type selected may vary depending on design requirements. Additionally, upon request, PBV Floating Ball Valves with standard trim fully comply with NACE MR0103.

### Firesafe ISO Design

PBV's 44/64 two-piece and 54 unibody valves are firesafe to API 607 or API 6FA. After the destruction of primary soft seals during a fire, complete metal-to-metal contact is attained at all sealing areas.

### Anti-Static Device

Internal parts insulated from the valve body by nonconductive seat and seal materials may build up a static electric charge. To ensure electrical continuity between the stem and the ball & body, PBV includes anti-static devices as an integral part of all floating ball valves.

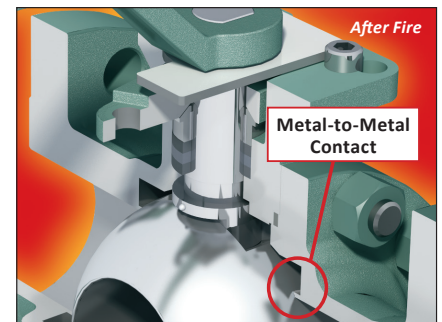

### Bi-directional, Downstream, Bubble-Tight Sealing

With the bi-directional sealing design, you can install either end upstream without compromising the integrity of the bubble-tight seal. Upstream pressure pushing against the ball cuts off media flow on the downstream side. Two rigid seats firmly secured in the valve body on either side of the ball achieve bubble-tight sealing.

### Live-Load and Fugitive Emissions Certified Stem Seals

Using Belleville spring washers achieves live loading and minimizes the need to retighten packing. Primary API 622 certified graphite stem seals are standard for all PBV ball valves, providing low break torque, excellent emission control, and good chemical and thermal resistance. PBV floating ball valves are fugitive emissions certified to API 641.

### Blowout Proof Stem and Ball Position Indicator

PBV accomplishes its blowout-proof stem feature by using a lower stem collar design. The stem is double-flat at the top to indicate the ball position.

### Equalized Cavity Pressure

The pressure equalization hole at the top of the ball, combined with the seat design, is engineered to maintain the pressure balance in the line and the body cavity while the valve is open.

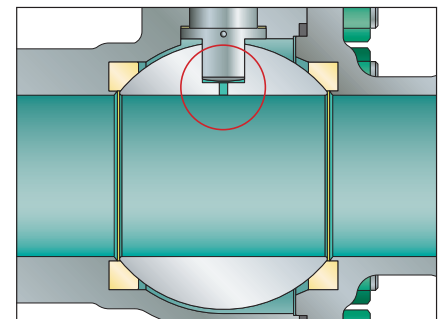

## HOW TO ORDER

### Specifying PBV 44/64 and 54 Figure Numbers

**Example:** P-6410-31-2236-GL-NL-I This number represents an International, Full Port, Two-piece Body, Stem Packed Flanged Floating Type, Class 150 Ball Valve, Fire Tested, with Raised Face End Connections, WCB Body with 316 Stainless Steel Trim, Glass Filled PTFE Seats, Graphite Seals, NACE Compliance, Lever Operated with ISO 5211 Mounting Pad.

**P - 6 4 10 - 3 1 - 22 36 - G L - N L - I**

Location Code	Port	Valve Type	Pressure Class	Tested	End Connection	Body	Trim	Seat	Stem Seal	NACE	Operator	Mounting	Modifier Code
<b>P</b> Import	<b>4</b> Reduced Port 2 Pc. Body	<b>4</b> Stem Packing Flanged Floating Type	<b>10</b> 150	<b>3</b> API 607 Fire Tested	<b>1</b> RF	<b>22</b> WCB	<b>00</b> Same as Body	<b>G</b> Glass Filled PTFE	<b>L</b> Graphite	<b>N</b> NACE	<b>L</b> Lever	<b>I</b> ISO 5211	<b>6D</b> API 6D Monogram
<b>D</b> Domestic	<b>5</b> Reduced Port Unibody		<b>30</b> 300	<b>4</b> API 641 Emissions & API 607 Fire Tested		<b>28</b> LCC	<b>36</b> 316SS	<b>P</b> PEEK™		<b>S</b> Non NACE	<b>G</b> Gear Operator		
	<b>6</b> Full Port 2 Pc. Body		<b>60</b> 600			<b>36</b> CF8M							

### Product Range

Size (in.)	44 Two-Piece Reduced Port			64 Two-Piece Full Port			54 Unibody Reduced Port	
	Pressure Class			Pressure Class			Pressure Class	
	150	300	600	150	300	600	150	300
3/4	—	—	—	•	•	•	—	—
1	—	—	—	•	•	•	•	•
1 1/2	—	—	—	•	•	•	•	•
2	•	•	•	•	•	•	•	•
3	•	•	•	•	•	• G	•	•
4	•	•	• G	•	•	• G	•	•
6	• S	•	• G	• G	• G	—	•	•
8	• G/S	• G	—	—	—	—	• G	• G

- G Gear Operated
- S ASME B16.10 Short Pattern End-to-End Length

# BALL VALVE STEM TORQUES

## PBV 44/64 and 54

### Stem Break Torque at Maximum Operating Pressure (in-lbs)

**Example:** A 4" full port (64) or 6" reduced port (44/54) class 300 valve with G/PTFE seats has a stem torque of 1541 in-lbs at maximum allowable working pressure.

Bore Size (in.)	STEM TORQUE (in-lbs)					
	G/PTFE Seat			PEEK Seat		
	Class 150 285 PSI	Class 300 740 PSI	Class 600 1480 PSI	Class 150 285 PSI	Class 300 740 PSI	Class 600 1480 PSI
3/4	26	49	86	39	73	129
1	54	99	173	81	149	259
1 1/2	113	220	393	170	330	590
2	179	391	736	269	587	1104
3	424	832	1494	636	1247	2241
4	697	1541	2913	1046	2311	4369
6	2215	4939	—	3323	7409	—

**NOTES:**

- 1) Torque values are for new valves with clean water service. No additional safety factors have been added.
- 2) For powered actuators, multiply values x 1.25.
- 4) For dirty service, multiply values x 1.3.
- 5) For dry gas service, multiply values x 1.25.
- 6) To prevent stem side loading and eliminate potential stem galling, we recommend the following tolerances for mounting actuators:
  - a) Actuator mounting bracket flanges must be parallel within .015".
  - b) The maximum allowed run out on the stem coupling bores are .008".

# FLOW COEFFICIENTS (Cv)

## PBV 44/64 and 54

By definition, Cv is the volume of water in gallons per minute at 60°F that will flow through a given element with a pressure drop of 1 psi.

Size (in.)	44 Two-Piece Reduced Port			64 Two-Piece Full Port			54 Unibody* Reduced Port	
	Pressure Class			Pressure Class			Pressure Class	
	150	300	600	150	300	600	150	300
3/4	—	—	—	46	41	37	—	—
1	—	—	—	88	77	67	75	78
1 1/2	—	—	—	223	207	184	230	226
2	176	206	245	467	424	365	211	236
3	210	276	323	1226	1041	928	445	724
4	510	689	907	2471	2140	1799	523	607
6	666	886	1157	5484	5416	—	654	760
8	1687	2485	—	—	—	—	1652	2013

\* Values calculated for preferred direction, Body Upstream

# PRESSURE/TEMPERATURE

## PBV 44/64 and 54

The body, seal, and seat material ratings determine the pressure-temperature ratings for PBV's Flanged Floating Ball Valves. The chart below indicates the standard seat materials. For ratings of other materials, contact your PBV customer service representative.

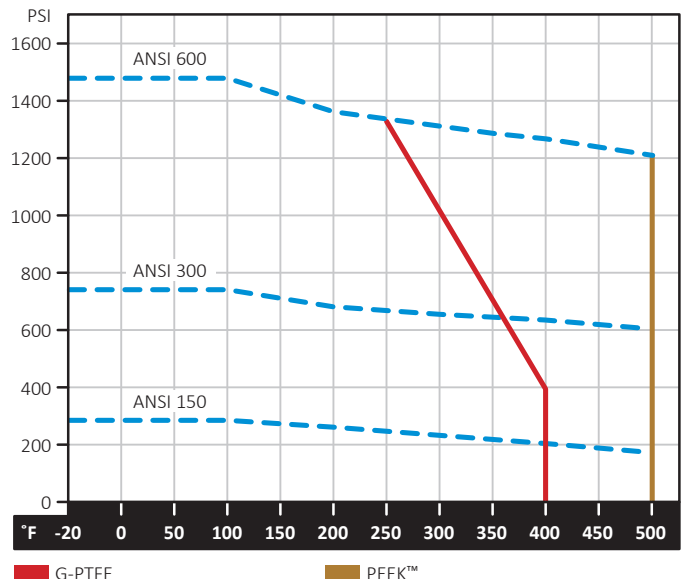

# PARTS & MATERIALS

## PBV 44/64 Two-Piece

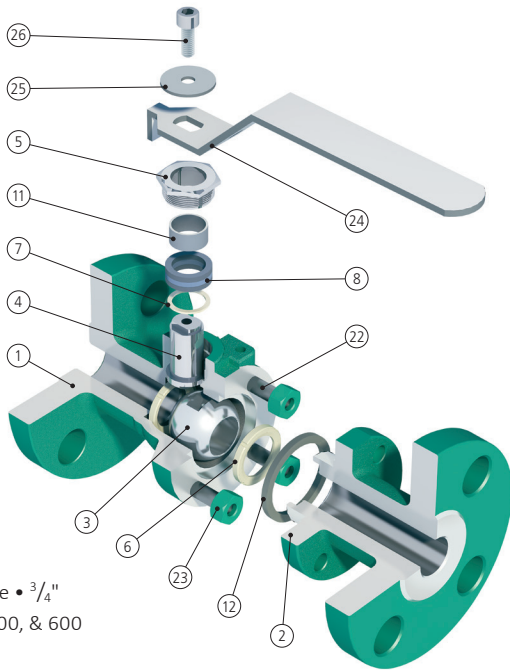

64 Two-Piece • 3/4" Class 150, 300, & 600

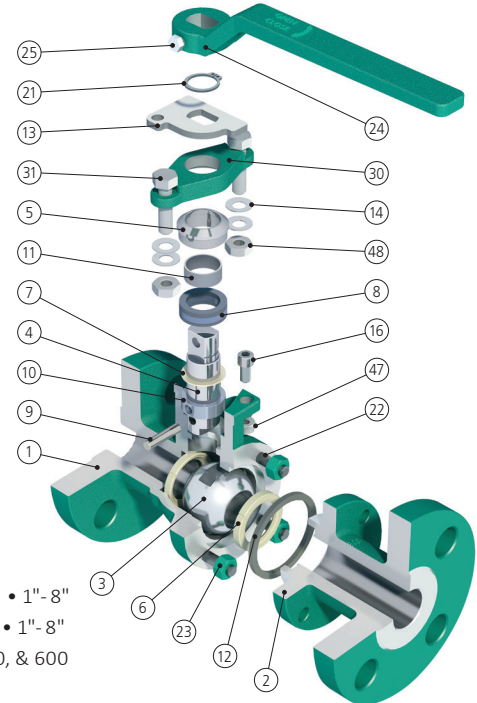

44 Two-Piece • 1"- 8" 64 Two-Piece • 1"- 8" Class 150, 300, & 600

### Standard Material Configuration

Item No.	Description	Material			Spares
1	Body	WCB	LCC	CF8M	
2	Cap	WCB	LCC	CF8M	
3	Ball	ASTM A351 CF8M			
4	Stem	ASTM A276 316			
5	Gland	ASTM A276 316			
6	Seats	G-PTFE			S
7	Stem Thrust Bearing	G-PTFE			S
8	Packing	Graphite			S
11	Gland Bushing	Virgin PTFE			S
12	Body Gasket	316L + Graphite			S
22	Stud	B7M	L7M	B8	
23	Nut	2HM	7M	B8	
24	Handle	Stainless Steel			
25	Handle Screw Washer	Stainless Steel			
26	Handle Screw	Stainless Steel			
	Nameplate	Stainless Steel			

### Standard Material Configuration

Item No.	Description	Material			Spares
1	Body	WCB	LCC	CF8M	
2	Cap	WCB	LCC	CF8M	
3	Ball	ASTM A351 CF8M			
4	Stem	ASTM A276 316			
5	Gland	ASTM A276 316			
6	Seats	G-PTFE			S
7	Stem Thrust Bearing	G-PTFE			S
8	Packing	Graphite			S
9*	Stem Pin	17-4 Stainless Steel			
10*	Stem Collar	316 Stainless Steel			
11	Gland Bushing	Virgin PTFE			S
12	Body Gasket	316L + Graphite			S
13	Stop Plate	Stainless Steel			
14	Spring Washer	Stainless Steel			
16	Stop	Stainless Steel			
21	Snap Ring	Stainless Steel			
22	Stud	B7M	L7M	B8	
23	Nut	2HM	7M	B8	
24**	Handle	ASTM A216 WCB			
25	Handle Screw	Stainless Steel			
30	Gland Plate	ASTM A351 CF8M			
31	Gland Bolts	ASTM A193 B8			
47	Stop Nut	Stainless Steel			
48	Gland Nut	Stainless Steel			
	Nameplate	Stainless Steel			

\* Items 9 and 10 only apply to 1 1/2" 44 and 1" 64  
 \*\* 4" bore and larger valves use a handle adaptor and pipe



# DIMENSIONAL DATA

## PBV 44 Two-Piece

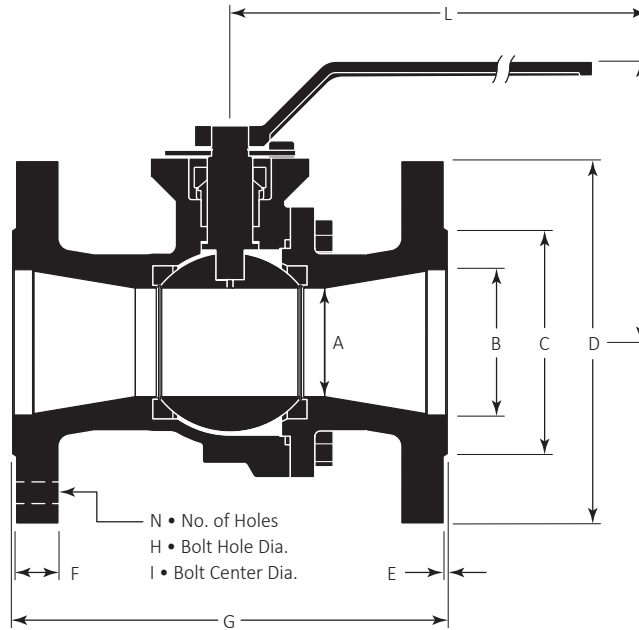

### 44 Two-Piece, 2" - 8", Class 150, 300, & 600

Size (in.)	Class	A	B	C	D	E	F	G	NxØH	I	J	L
2	150	1.50	2.00	3.62	6.0	0.06	0.56	7.0	4 x .75	4.75	6.1	9.7
	300	1.50	2.00	3.62	6.5	0.06	0.81	8.5	8 x .75	5.00	6.1	9.7
	600	1.50	2.00	3.62	6.5	0.25	1.00	11.5	8 x .75	5.00	6.0	9.7
3	150	2.00	3.00	5.00	7.5	0.06	0.69	8.0	4 x .75	6.00	6.5	9.7
	300	2.00	3.00	5.00	8.3	0.06	1.06	11.1	8 x .88	6.62	6.5	9.7
	600	2.00	3.00	5.00	8.3	0.25	1.25	14.0	8 x .88	6.62	6.7	9.7
4	150	3.00	4.00	6.19	9.0	0.06	0.88	9.0	8 x .75	7.50	7.8	14.0
	300	3.00	4.00	6.19	10.0	0.06	1.19	12.0	8 x .88	7.88	7.8	14.0
	600	3.00	4.00	6.19	10.8	0.25	1.50	17.0	8x1.00	8.50	8.3	19.8
6	150	4.00	6.00	8.50	11.0	0.06	0.94	10.5*	8 x .88	9.50	8.5	19.8
	300	4.00	6.00	8.50	12.5	0.06	1.38	15.9	12x.88	10.62	9.1	19.8
	600	4.00	6.00	8.50	14.0	0.25	1.88	22.0	8x1.12	11.50	10.2	19.8
8	150	6.00	8.00	10.63	13.6	0.06	1.06	11.5*	8 x .88	11.75	—	—
	300	6.00	8.00	10.63	15.0	0.06	1.56	19.8	12x1.00	13.00	—	—

\* ASME B16.10 Short Pattern Face-to-Face

NOTE: Dimensions are in inches.

## DIMENSIONAL DATA

### PBV 64 Two-Piece

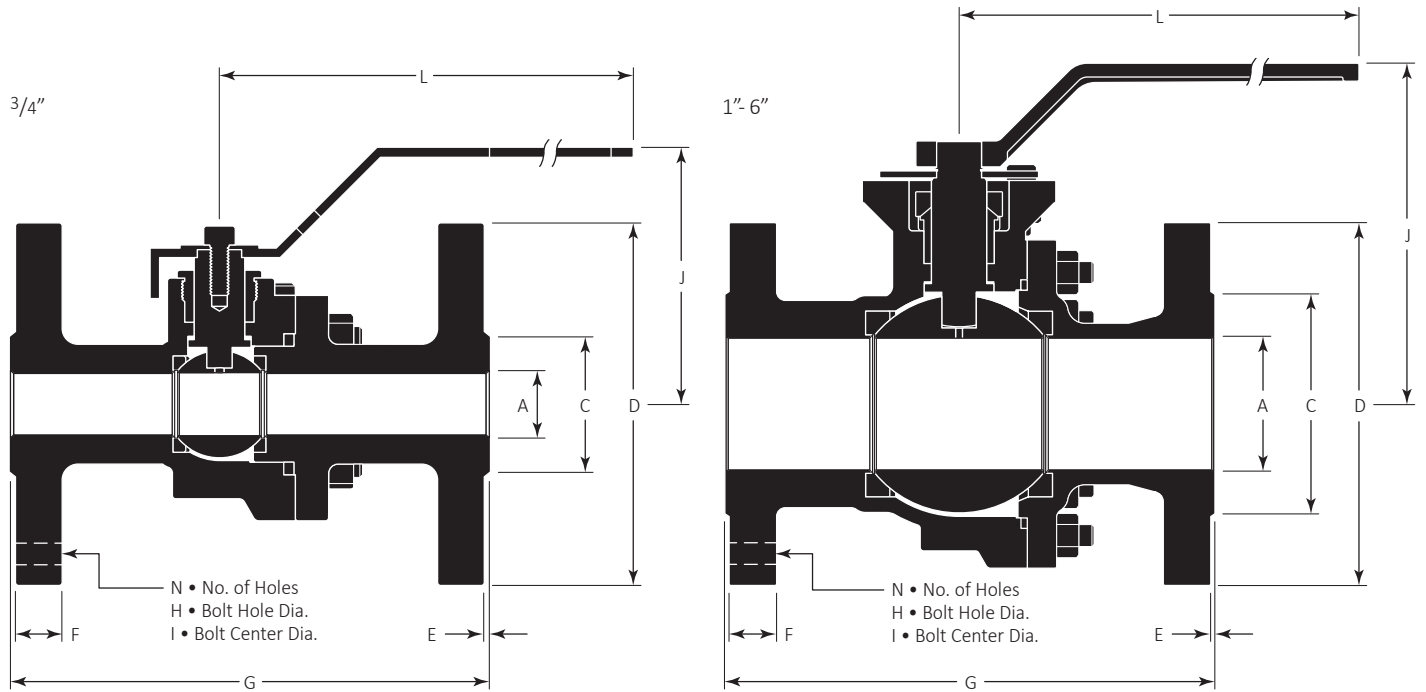

### 64 Two-Piece, 3/4" - 6", Class 150, 300, & 600

Size (in.)	Class	A	C	D	E	F	G	N x ØH	I	J	L
3/4	150	0.79	1.69	3.9	0.06	0.34	4.6	4 x .63	2.75	3.2	6.6
	300	0.79	1.69	4.6	0.06	0.56	6.0	4 x .75	3.25	3.2	6.6
	600	0.79	1.69	4.6	0.25	0.62	7.5	4 x .75	3.25	3.2	6.6
1	150	1.00	2.00	4.3	0.06	0.38	5.0	4 x .63	3.13	4.2	7.0
	300	1.00	2.00	4.9	0.06	0.62	6.5	4 x .75	3.50	4.2	7.0
	600	1.00	2.00	4.9	0.25	0.69	8.5	4 x .75	3.50	4.2	7.0
1 1/2	150	1.50	2.87	5.0	0.06	0.50	6.5	4 x .63	3.87	6.1	9.7
	300	1.50	2.87	6.1	0.06	0.75	7.5	4 x .88	4.50	6.1	9.7
	600	1.50	2.87	6.1	0.25	0.88	9.5	4 x .88	4.50	6.1	9.7
2	150	2.00	3.63	6.0	0.06	0.56	7.0	4 x .75	4.75	6.5	9.7
	300	2.00	3.63	6.5	0.06	0.81	8.5	8 x .75	5.00	6.5	9.7
	600	2.00	3.63	6.5	0.25	1.00	11.5	8 x .75	5.00	6.7	9.7
3	150	3.00	5.00	7.5	0.06	0.69	8.0	4 x .75	6.00	7.7	14.0
	300	3.00	5.00	8.3	0.06	1.06	11.1	8 x .88	6.62	7.7	14.0
	600	3.00	5.00	8.3	0.25	1.25	14.0	8 x .88	6.62	7.7	19.8
4	150	4.00	6.12	9.0	0.06	0.88	9.0	8 x .75	7.50	8.5	19.8
	300	4.00	6.12	10.0	0.06	1.19	12.0	8 x .88	7.87	8.5	19.8
	600	4.00	6.20	10.8	0.25	1.50	17.0	8 x 1.00	8.50	9.1	19.8
6	150	6.00	8.50	11.0	0.06	0.94	15.5	8 x .88	9.50	—	—
	300	6.00	8.50	12.5	0.06	1.38	15.9	12 x .88	10.62	—	—

NOTE: Dimensions are in inches.

# MOUNTING & WEIGHTS

## PBV 44 Two-Piece

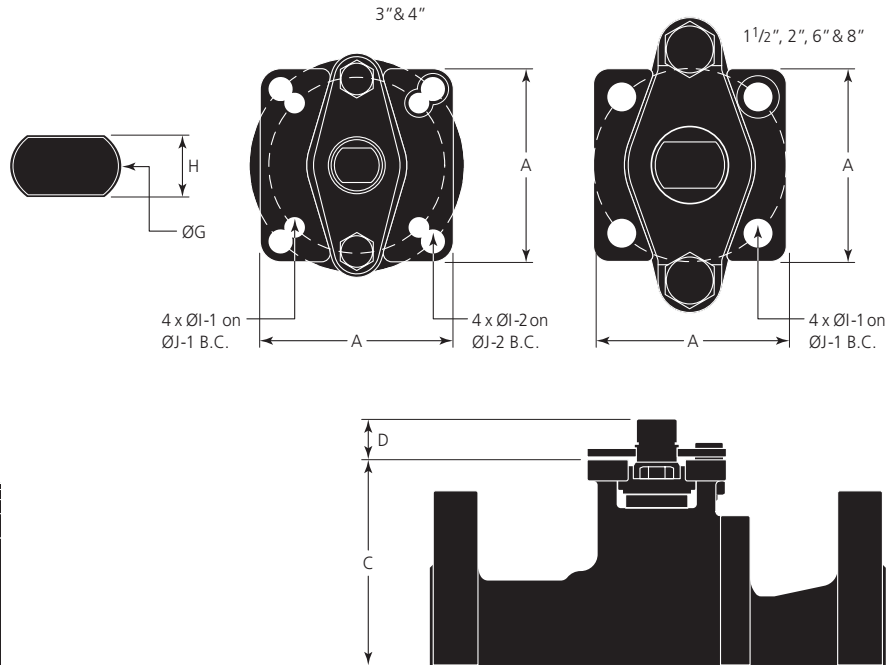

### 44 Two-Piece, 2" - 8", Class 150, 300, & 600

Size (in.)	Class	A	C	D	ØG	H	I-1	ØJ-1	ISO 5211	I-2	ØJ-2	ISO 5211
2	150	2.60	3.43	0.77	0.748	0.551	0.394	2.756	F07	—	—	—
	300	2.60	3.43	0.77	0.748	0.551	0.394	2.756	F07	—	—	—
	600	2.60	3.43	0.77	0.748	0.551	0.394	2.756	F07	—	—	—
3	150	2.60	3.83	0.77	0.866	0.630	0.394	2.756	F07	—	—	—
	300	2.60	3.83	0.77	0.866	0.630	0.394	2.756	F07	—	—	—
	600	3.54	4.03	0.77	0.866	0.630	0.394	2.756	F07	0.472	4.016	F10
4	150	4.41	5.09	0.87	1.024	0.787	0.472	4.016	F10	0.551	4.921	F12
	300	4.41	5.09	0.89	1.024	0.787	0.472	4.016	F10	0.551	4.921	F12
	600	4.41	5.71	1.06	1.181	0.945	0.472	4.016	F10	0.551	4.921	F12
6	150	4.41	5.93	1.02	1.181	0.945	0.472	4.016	F10	0.551	4.921	F12
	300	4.41	6.55	1.05	1.181	0.945	0.472	4.016	F10	0.551	4.921	F12
	600	4.41	7.63	1.06	1.181	0.945	0.472	4.016	F10	0.551	4.921	F12
8	150	4.41	8.50	1.14	1.575	1.181	0.551	4.921	F12	—	—	—
	300	4.41	8.50	1.14	1.575	1.181	0.551	4.921	F12	—	—	—

NOTE: Dimensions are in inches.

### Approximate Valve Weights (lbs.)

Pressure Class	Size (in.)						
	1	1 1/2	2	3	4	6	8
150	9	13	19	34	66	102	227
300	13	19	27	48	89	165	326
600	14	23	35	63	137	268	—

# MOUNTING & WEIGHTS

## PBV 64 Two-Piece

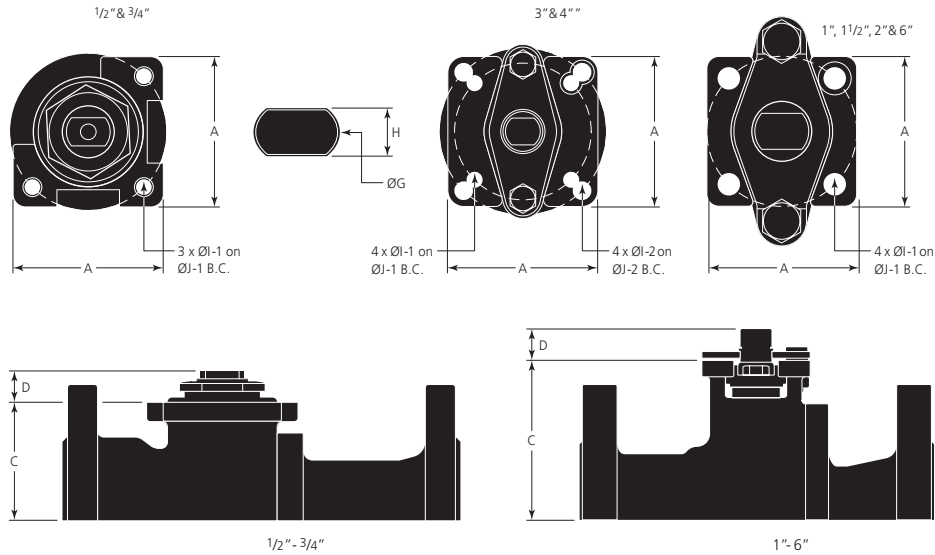

### 64 Two-Piece, 3/4" - 6", Class 150, 300, & 600

Size (in.)	Class	A	C	D	ØG	H	I-1	ØJ-1	ISO 5211	I-2	ØJ-2	ISO 5211
3/4	150	1.89	1.52	0.41	0.551	0.354	M6x10-65	1.969	F05	—	—	—
	300	1.89	1.52	0.41	0.551	0.354	M6x10-65	1.969	F05	—	—	—
	600	1.81	1.52	0.39	0.551	0.551	M6x10-65	1.969	F05	—	—	—
1	150	1.97	2.65	0.76	0.709	0.472	0.295	1.969	F05	—	—	—
	300	1.97	2.65	0.76	0.709	0.472	0.295	1.969	F05	—	—	—
	600	1.97	2.65	0.76	0.709	0.472	0.295	1.969	F05	—	—	—
1 1/2	150	2.60	3.43	0.77	0.748	0.551	0.394	2.756	F07	—	—	—
	300	2.60	3.43	0.77	0.748	0.551	0.394	2.756	F07	—	—	—
	600	2.60	3.43	0.76	0.748	0.551	0.394	2.756	F07	—	—	—
2	150	2.60	3.83	0.77	0.866	0.630	0.394	2.756	F07	—	—	—
	300	2.60	3.83	0.77	0.866	0.630	0.394	2.756	F07	—	—	—
	600	2.60	4.03	0.77	0.866	0.630	0.394	2.756	F07	—	—	—
3	150	4.41	5.09	0.89	1.024	0.787	0.472	4.016	F10	0.551	4.921	F12
	300	4.41	5.09	0.89	1.024	0.787	0.472	4.016	F10	0.551	4.921	F12
	600	4.41	5.10	1.02	1.181	0.945	0.472	4.016	F10	0.551	4.921	F12
4	150	4.41	5.93	1.02	1.181	0.945	0.472	4.016	F10	0.551	4.921	F12
	300	4.41	5.91	1.06	1.181	0.945	0.472	4.016	F10	0.551	4.921	F12
	600	4.41	6.57	1.02	1.181	0.945	0.472	4.016	F10	0.551	4.921	F12
6	150	4.41	8.50	1.14	1.496	1.181	0.551	4.921	F12	—	—	—
	300	4.41	8.50	1.14	1.496	1.181	0.551	4.921	F12	—	—	—

NOTE: Dimensions are in inches.

### Approximate Valve Weights (lbs.)

Class	Size (in.)						
	3/4	1	1 1/2	2	3	4	6
150	6	9	17.4	25	54	88	214
300	9	13	24	32	69	119	269
600	10	15	29	42	92	180	—

# PARTS & MATERIALS

## PBV 54 Unibody

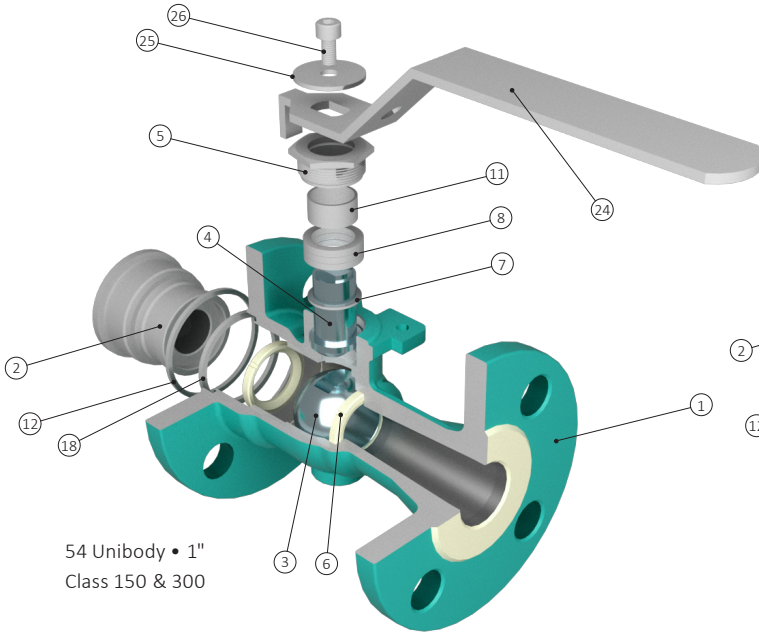

54 Unibody • 1"  
Class 150 & 300

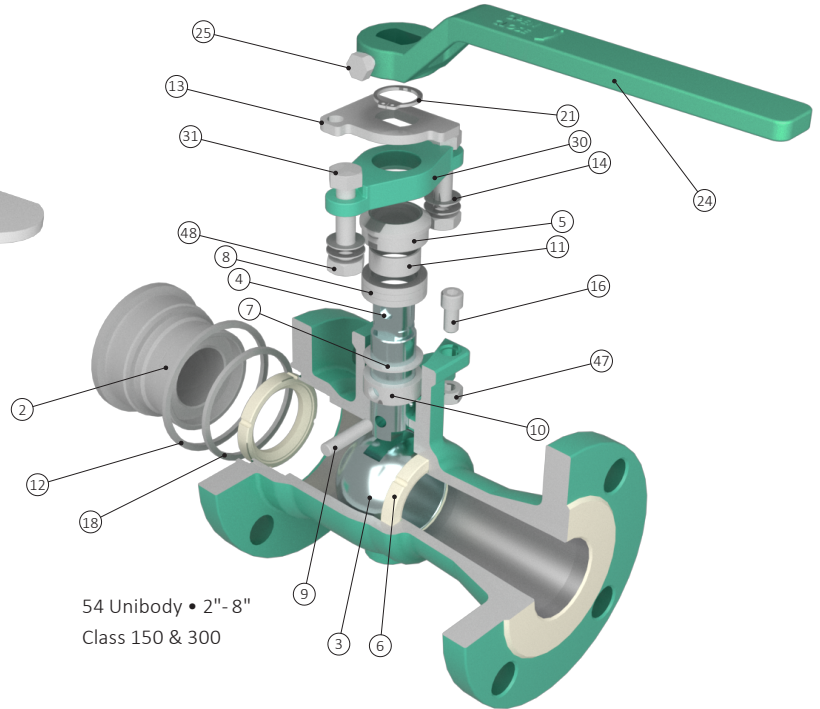

54 Unibody • 2"- 8"  
Class 150 & 300

### Standard Material Configuration

Item No.	Description	Material			Spares
1	Body	WCB	LCC	CF8M	
2	Insert	WCB	LCC	CF8M	
3	Ball	316 Stainless Steel			
4	Stem	316 Stainless Steel			
5	Gland	316 Stainless Steel			
6	Seats	G-PTFE			S
7	Stem Thrust Bearing	G-PTFE			S
8	Packing	Graphite			S
11	Gland Bushing	Virgin PTFE			S
12	Body Gasket	Graphite			S
18	Body Gasket	Virgin PTFE			S
24	Handle	Stainless Steel			
25	Handle Screw	Stainless Steel			
26	Handle Washer	Stainless Steel			
	Nameplate	Stainless Steel			

### Standard Material Configuration

Item No.	Description	Material			Spares
1	Body	WCB	LCC	CF8M	
2	Insert	WCB	LCC	CF8M	
3	Ball	316 Stainless Steel			
4	Stem	316 Stainless Steel			
5	Gland	316 Stainless Steel			
6	Seats	G-PTFE			S
7	Stem Thrust Bearing	G-PTFE			S
8	Packing	Graphite			S
9*	Stem Pin	17-4 Stainless Steel			
10*	Stem Collar	316 Stainless Steel			
11	Gland Bushing	Virgin PTFE			S
12	Body Gasket	Graphite			S
13	Stop Plate	Stainless Steel			
14	Spring Washer	Stainless Steel			
16	Stop	Stainless Steel			
18	Body Gasket	Virgin PTFE			S
21	Snap Ring	Stainless Steel			
24**	Handle	ASTM A216 WCB			
25	Handle Screw	Stainless Steel			
30	Gland Plate	ASTM A351 CF8			
31	Gland Bolts	ASTM A193 B8			
47	Stop Nut	Stainless Steel			
48	Gland Nut	Stainless Steel			
	Nameplate	Stainless Steel			

\* Items 9 and 10 only apply to 1 1/2" 54

\*\* 6" valves and above use a handle adaptor and pipe

## DIMENSIONAL DATA

### PBV 54 Unibody

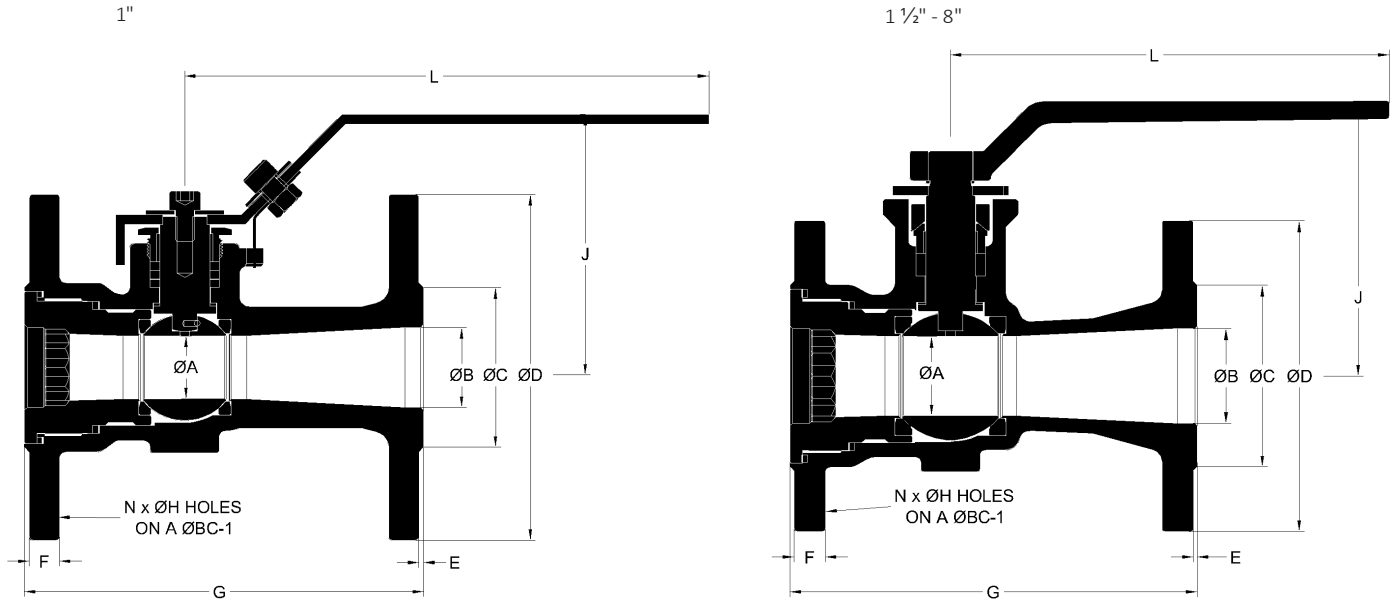

#### 54 Unibody, 1" - 8", Class 150 & 300

Size (in.)	Class	A	B	C	D	E	F	G	N x ØH	I	J	L
1	150	0.79	1.00	2.00	4.25	0.06	0.38	5.0	4 x .63	3.12	3.20	6.60
	300	0.79	1.00	2.00	4.88	0.06	0.62	6.50	4 x .75	3.50	3.20	6.60
1 1/2	150	1.26	1.50	2.87	5.00	0.06	0.50	6.50	4 x .63	3.88	4.40	7.00
	300	1.26	1.50	2.87	6.10	0.06	0.75	7.50	4 x .87	4.50	4.80	7.00
2	150	1.50	1.97	3.62	5.98	0.06	0.56	7.00	4 x .75	4.75	6.10	9.70
	300	1.50	2.00	3.62	6.50	0.06	0.81	8.50	8 x .75	5.00	6.10	9.70
3	150	2.44	3.00	5.00	7.48	0.06	0.69	8.00	4 x .75	6.00	6.70	9.70
	300	2.44	3.00	5.00	8.27	0.06	1.06	11.12	8 x .87	6.62	7.10	9.70
4	150	3.00	4.02	6.19	9.02	0.06	0.88	9.0	8 x .75	7.50	7.80	14.00
	300	3.00	4.02	6.19	10.00	0.06	1.19	12.00	8 x .87	7.88	7.90	14.00
6	150	4.02	6.00	8.50	10.98	0.06	0.94	10.50	8 x .87	9.50	9.10	19.80
	300	4.02	6.00	8.50	12.52	0.06	1.38	15.90	12 x .87	10.62	8.40	19.80
8	150	5.90	7.91	10.62	13.50	0.06	1.06	11.50	8 x 0.87	11.75	10.20	34.20
	300	5.90	7.91	10.62	15.00	0.06	1.56	16.50	12 x 1.00	13.00	10.20	34.20

NOTE: Dimensions are in inches.

# MOUNTING & WEIGHTS

## PBV 54 Unibody

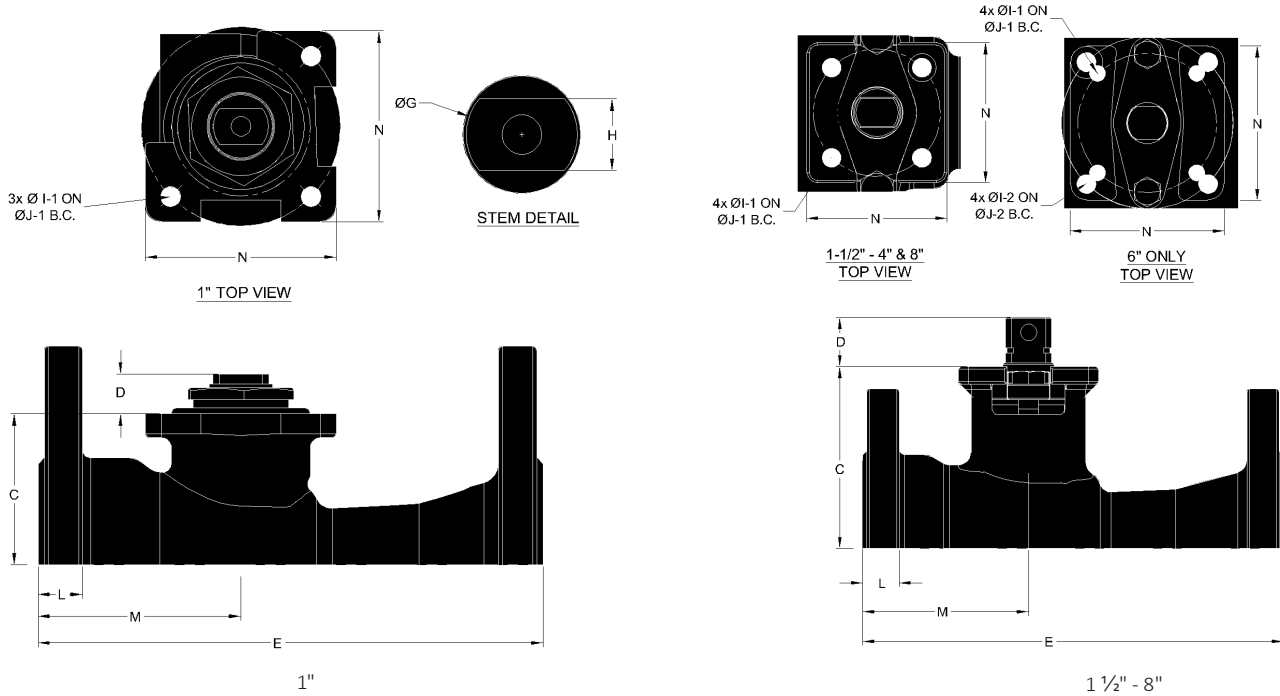

### 54 Unibody, 1" - 8", Class 150 & 300

Size (in.)	Class	ØK	L	M	N	C	D	E	ØG	H	Ø1-1	ØJ-1	Ø1-2	ØJ-2	ISO 5211
1	150	4.33	0.44	2.01	1.89	1.50	0.39	5.00	0.55	0.35	0.20	1.97	—	—	F05
	300	5.00	0.69	2.48	1.89	1.50	0.39	6.50	0.55	0.35	0.20	1.97	—	—	F05
1 1/2	150	4.92	0.58	2.56	2.17	2.81	0.76	6.50	0.71	0.47	0.30	1.97	—	—	F05
	300	6.10	0.81	3.07	2.17	2.23	0.76	7.18	0.71	0.47	0.30	1.97	—	—	F05
2	150	5.98	0.63	2.95	2.6	3.43	0.77	7.01	0.87	0.63	0.39	2.76	—	—	F07
	300	6.50	0.88	3.43	2.60	3.43	0.77	8.50	0.87	0.63	0.39	2.76	—	—	F07
3	150	7.48	0.75	3.12	2.60	4.05	0.8	7.99	0.87	0.63	0.39	2.76	—	—	F07
	300	8.27	1.13	3.51	2.60	4.40	0.77	11.10	0.87	0.63	0.39	2.76	—	—	F07
4	150	9.06	0.94	4.33	3.62	5.13	0.89	9.00	1.02	0.79	0.47	4.02	—	—	F10
	300	10.04	1.25	4.59	3.62	5.18	0.90	12.01	1.02	0.79	0.47	4.02	—	—	F10
6	150	11.02	1.00	4.72	4.41	5.93	1.02	10.51	1.18	0.94	0.47	4.02	0.55	4.92	F10/F12
	300	12.60	1.44	4.80	4.41	6.52	1.02	15.87	1.18	0.94	0.47	4.02	0.55	4.92	F10/F12
8	150	13.58	1.13	5.83	4.41	8.18	1.14	11.50	1.50	1.18	0.55	4.92	—	—	F12
	300	14.96	1.63	5.83	4.41	8.18	1.14	16.50	1.50	1.18	0.55	4.92	—	—	F12

NOTE: Dimensions are in inches.

### Approximate Valve Weights (lbs.)

Class	Size (in.)						
	1	1 1/2	2	3	4	6	8
150	5.7	11.1	18.6	32.4	61.7	103.4	201.7
300	9.7	18.9	28	48.7	86.2	156.5	282



## OUR CORE VALUES

### No One Gets Hurt

The safety of our employees and customers is our first priority coupled with a healthy respect for the environment.

### Integrity

In everything we do, in every interaction, both internally and externally, we strive to operate with the utmost integrity and mutual respect.

### Customer Focused

Our products enhance our customer's performance and we listen to their needs and work with them to solve their challenges.

### Good Place To Work

We are committed to creating a workplace that fosters innovation, teamwork and pride. Every team member is integral to our success and is treated equally and fairly.

---

### FORUM ENERGY TECHNOLOGIES

 12735 Dairy Ashford Road  
Stafford, TX 77477

 +1 281 637 2000 (General)  
+1 281 637 2097 (Sales)

 [f-e-t.com/valve-solutions](http://f-e-t.com/valve-solutions)

 [ForumVS.Sales@f-e-t.com](mailto:ForumVS.Sales@f-e-t.com)

The information provided in this brochure is intended for informational purposes only. While we strive to maintain accuracy, please know that the content may change without prior notification. We do not guarantee the information's completeness, timeliness, or reliability. Any reliance on the content is at your discretion, and we assume no responsibility for errors, omissions, or inaccuracies that may occur.

Copyright © FORUM ENERGY TECHNOLOGIES, INC. All rights reserved. • PBV is a registered trademark of Forum US, Inc.

VS PBV44/64\_54.0924