

## PBV<sup>®</sup> 57/67

### THREE-PIECE TRUNNION BALL VALVES

 +1 281 637 2000

 [f-e-t.com/PBV](http://f-e-t.com/PBV)

 [ForumVS.PBV@f-e-t.com](mailto:ForumVS.PBV@f-e-t.com)

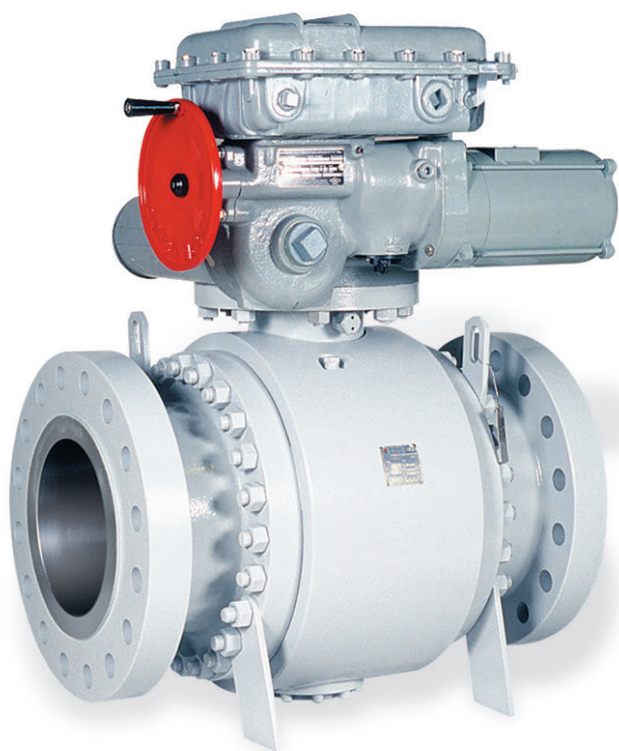

## MANUFACTURER OF QUALITY VALVE PRODUCTS AROUND THE GLOBE

Forum Energy Technologies (FET) is committed to improving our clients’ operational and financial performance by supplying the most comprehensive range of valve products in the industry through our family of trusted valve brands.



## ABOUT FET

### Engineering Expertise

FET uses the latest state-of-the-art engineering software to provide custom design services for any application. Finite element analysis is just one of many Design Verification Tools FET uses to design valves to specific customer requirements.

### CAD & CNC Capabilities

With FET’s fast and efficient workflow, CAD drawings are releasable to the network for manufacturing and purchasing. Computer-generated machine programs can be quickly changed for weld overlays or other processes, resulting in faster deliveries.

### Accurate Inventories

Daily cycle counting and order picking using barcode and automated part delivery systems results in more accurate inventories and faster product delivery.

### Quality Control

All FET Companies manufacture quality products designed and tested to meet the standards of Qualifying Authorities worldwide. Advanced engineering and our Quality Management System ensure that our valve products continue to exceed your expectations for performance.

### Customer Service

FET staffs its Customer Service Department with trained representatives ready to help you with ordering information, technical specifications, and logistics.

## Contents

Design Standards & Specifications .....	3	<b>2" Full Port - 6" Reduced Port</b>	
Design Features .....	4-5	Parts List.....	10
How to Order .....	6	Dimensional Data.....	11-12
Product Range .....	6	<b>6" Full Port - 14" Reduced Port</b>	
Ball Valve Stem Torques .....	7	Parts List .....	13
Flow Coefficients (Cv) .....	7	Dimensional Data .....	14-15
Pressure Temperature .....	8	<b>16" Full Port - 36" Full Port</b>	
Block and Bleed Defined .....	8	Parts List .....	16
Modifications, Services, and Repair Kits .....	9	Dimensional Data .....	17-18
		<b>Shipping Information</b> .....	19

*Due to upgrades in industry standards, material innovations, and FET/PBV's constant commitment to product advancement, data presented in this brochure are subject to change. Please contact your PBV sales representative for updated and current drawings and material compliance.*

**Note:** Data contained in this document is for informational purposes and shall not be used for design purposes.

## DESIGN STANDARDS & SPECIFICATIONS

### Certification of Quality and Design

Quality systems are a way of life at PBV. In addition, PBV functions under the requirements of an API Q1 quality program. Our facilities and quality programs are always open to customer audits. PBV maintains active involvement in API, ASME, and MSS standards organizations.

### PBV Quality Procedures

Tests and inspections on every valve are performed throughout production to ensure products meet PBV quality standards. Quality holdpoints include receiving inspection, pressure testing, and final inspection to confirm the performance of all marking, tagging, and processing according to PBV and leading industry standards.

### PBV Trunnion Ball Valves are designed to meet the following industry standards.

#### **American Petroleum Institute**

- API 6D • Specifications for Pipeline Valves
- API 598 • Valve Inspection and Testing
- API 607 • Fire Test for Soft-Seated Ball Valves
- API Q1 • Specifications for Quality Programs
- API 6FA • Fire Test for Valves\*

#### **Manufacturers Standardization Society**

- MSS SP-25 • Standard Marking System for Valves
- MSS SP-55 • Quality Standard for Steel Castings for Valves

#### **National Association of Corrosion Engineers**

- NACE MR0175 • Sulfide Stress Cracking Resistant Metallic Materials for Oilfield Equipment
- NACE MR0103 • Metallic Materials Resistant to Sulfide Stress Cracking in Corrosive Petroleum Refining Environments\*

#### **American National Standards**

- ASME/ANSI B16.34 • Valves — Flanged, Threaded, and Welding Ends
- ASME/ANSI B16.10 • Face-to-Face and End-to-End Dimensions on Ferrous Valves
- ASME/ANSI B16.5 • Steel Pipe Flanges and Flanged Fittings
- ASME B31.1 • Power Piping
- ASME B31.3 • Process Piping
- ASME B31.4 • Pipeline Transportation Systems for Liquids and Slurries
- ASME B31.8 • Gas Transmission and Distribution Piping Systems

#### **International Standards Organization**

- ISO 15848-1 • Industrial Valves Measurement, Test and Qualification Procedures for Fugitive Emissions
- ISO 9001 • Quality Management Systems — Requirements
- ISO 5211 • Industrial Valves — Part-Turn Actuator Attachments

#### **Code of Federal Regulations**

- Title 49 Part 192 • Transportation of Natural and Other Gas by Pipeline

#### **European Community**

- PED • Pressure Equipment Directive / CE\*

\* Available upon request

# PBV ENGINEERING EXCELLENCE AT WORK

## PBV Series 57/67 Three-Piece Trunnion Ball Valve

PBV's trunnion ball valves are available in a variety of materials and configurations to meet your specific project requirements. Typical construction is shown here.

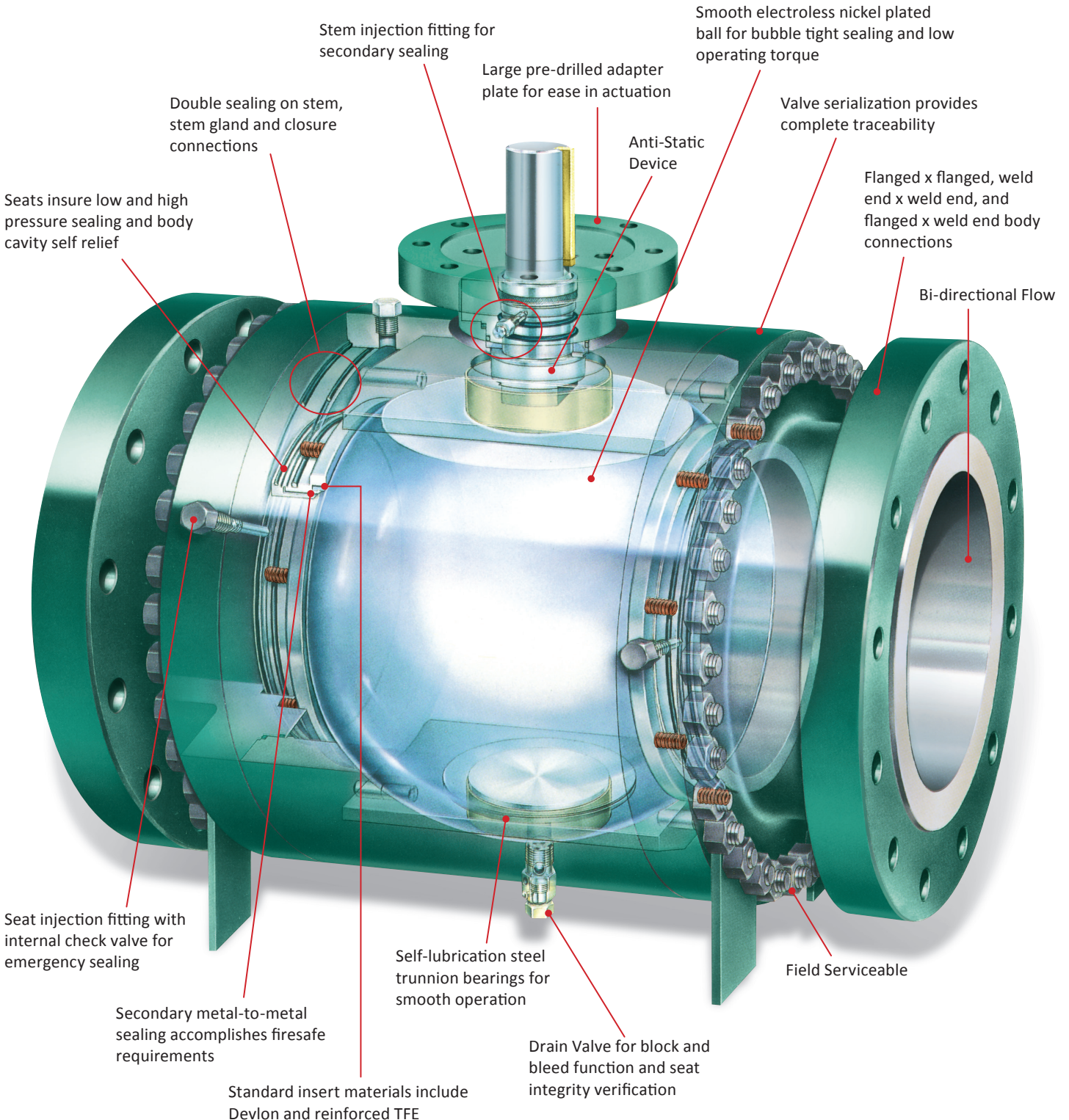

## FEATURES

### Construction Materials

PBV manufactures trunnion ball valves using a full range of carbon, alloy, and stainless materials. Our trunnion valves are manufactured using dual-rated A105/A350 LF2 steel, B7M/ 2HM fasteners, and 3mil ENP carbon steel trim on 6" and larger. Material test reports in accordance with EN10204 3.1b are available on each serialized valve.

### NACE Compliance

All materials used by PBV follow the pre-qualified materials identified by NACE MR0175/ISO 15156. Customers must provide application-specific operating conditions to ensure compliance. Additionally, valves with 4" and smaller bore diameters are supplied standard with stainless steel balls, seats, and stems. The material type selected may vary depending on design requirements.

### Emergency Sealant Injection

All PBV Trunnion ball valves include a secondary sealant injection system for stem seals. The seat emergency sealant system is also a standard feature on valves with a 6" bore and larger. A similar system is available on request for sizes 2" through 4". These systems are made available to temporarily seal an otherwise damaged area. PBV ball valves require no lubrication under ordinary circumstances.

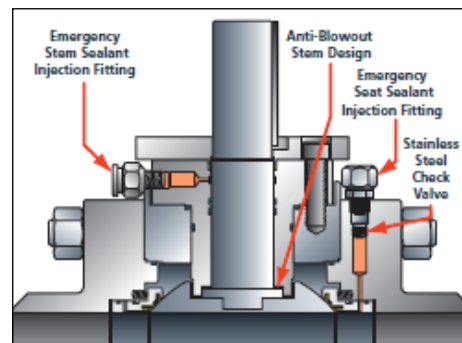

### Double Block and Bleed Valves

PBV designs and manufactures all trunnion-mounted ball valves to facilitate only block and bleed applications in the closed position. Also, you can thoroughly flush valves 6" and larger with the valve under pressure and in the closed position by utilizing the drain valve and vent hole in combination. The illustration on the right shows both the upstream pressure (Pu) and the downstream pressure (Pd) being held independently from the body pressure (Pb). The piston effect principle ensures bubble-tight sealing simultaneously on both sides of the ball.

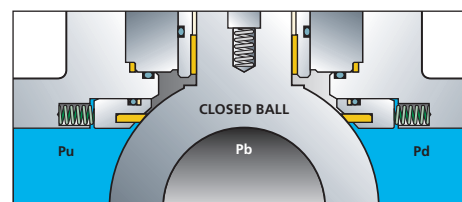

Shown In Closed Position.

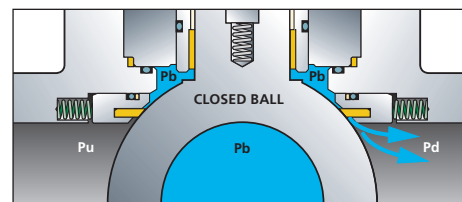

Shown In Closed Position.

### Valve Cavity Pressure Relief SPE x SPE (Self-Relieve Seat Design)

When a trunnion ball valve is in the closed position, media gets trapped in the body cavity. Unless drained, this media will be subjected to thermal expansion and contraction. As the temperature rises, the trapped media desires to expand and the pressure increases in the (Pb) area, as shown in the illustrations on the right. To avoid excessive pressure build-up in the PBV seats, they are designed to self-relieve, allowing the media in the body to escape to the pipeline. In this case, we have shown that it relieves the downstream side (Pd).

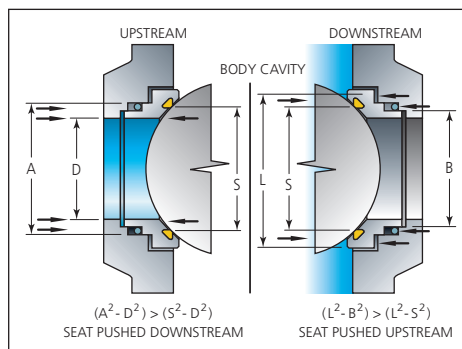

Illustration 2

### DPE X DPE (Double Piston Effect)

Seats with soft sealing rings are automatically supplied as DPE designs (see Illustration 2). DPE design means that if the upstream seat is damaged, the function of a ball valve is still secured by a downstream seat. A two-way seat design is often necessary to meet customers' diverse requirements. This flexible design allows for downstream seat sealing when an upstream seat fails to seal, accommodating various operational scenarios.

### Locking Device

Locking devices are standard on all PBV trunnion ball valves. The illustrations depict the locking feature for both lever-operated and gear-operated valves. In addition, a multiple lock template can accommodate safety requirements when more than one person needs security reassurance. Special safety interlock devices are also available.

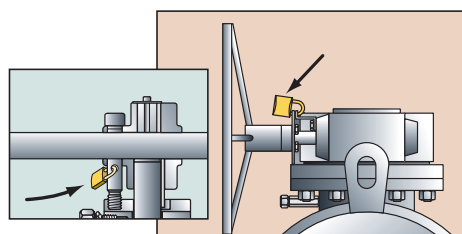

# HOW TO ORDER

## Specifying PBV 57/67 Trunnion Ball Valve, Figure Number

**Example: 6" C-6710-71-2200-GH-NG-DIB-1** This number represents a 6" ANSI Class 150, Full Port, Three-Piece Trunnion Ball Valve, Fire Tested with Emergency Grease Seals, with Raised Face, Carbon Steel Body Material, Carbon Steel Trim, Glass Filled TFE Seats, HNBR Seals, for NACE MR0175/ ISO 15156 Service, Gear Operated, and DIB-1 Seats, with Cavity Relief Valve.

Material Code	Port	Valve Type	Pressure Class	Fire Tested	End Conn.	Body Material	Trim Material	Seat Material	Seal Material	NACE Option	Operator	Seat Config.	Modifier Code		
C/S Domestic	5 Reduced	7 3-Piece Trunnion	10 150	7 Fire Tested w/ Emerg. Grease Seals	1 RF	22 A105/A350 LF2	00 Same as Body	G Glass Filled PTFE	E EPDM	N NACE	A Actuator	DIB-1 DPE x DPE	EXX Stem Extens. inches		
P Import	6 Full		30 300		3 RTJ	25 <sup>(1)</sup> A105/A350 LF2	36 <sup>(2)</sup> Stainless Steel	D DEVLON	H <sup>(2)</sup> HNBR		K Kalrez	B Bare Stem	DIB-1N DPE x DPE No Cavity Relief	XXX Modifier Code	
			60 600		4 RF x WE	34 304SS	40 410 Stainless Steel	N Nylon	U <sup>(1)</sup> Viton GLT		V Viton A	G Gear Operator	DIB-2N SPE x DPE No Cavity Relief	HXXX Buried Valve Extens. inches	
			90 900		5 WE x WE	36 316SS	55 F55 Duplex	P PEEK	V Viton <sup>®</sup> A		W <sup>(2)</sup> Viton B	L Lever	DBB SPE x SPE No Cavity Relief	PXXX Pinion Shaft Extens. inches	
			15 1500		6 RTJ x WE	81 ENP	82 CRA Weld Overlay	Z Tungsten Carbide Coating or Special						SXXX 2" Nut Extens. inches	
			25 2500												

- NOTES:** 1) Dual Rated A105/A350 LF2 - Low Temperature Service  
 2) For Explosive Decompression Service.  
 3) For "36" trim, large diameter and Class 900 and higher, 17-4PH material is standard for ball and stem. All valves 6" and larger have 17-4PH stems when "36" trim is specified. Stronger material may be used to satisfy design requirements. Stems can be 316SS, 17-4PH, etc.  
 4) Standard seat material for 150-300 GPTFE, Class 600 and above is DEVLON.

Material not listed consult factory.

# PRODUCT RANGE

Size (in.)	57 Three-Piece						67 Three-Piece					
	Pressure Class						Pressure Class					
	150	300	600	900	1500	2500	150	300	600	900	1500	2500
2	—	—	—	—	—	—	•	•	•	•	•	•
3	•	•	•	•	•	•	•	•	•	•	•	•
4	•	•	•	•	•	•	•	•	•	•	•	•
6	•	•	•	•	•	•	•	•	•	•	•	•
8	•	•	•	•	•	•	•	•	•	•	•	•
10	•	•	•	•	•	•	•	•	•	•	•	•
12	•	•	•	•	•	•	•	•	•	•	•	•
14	•	•	•	•	•	—	•	•	•	•	•	—
16	•	•	•	•	•	—	•	•	•	•	•	—
18	•	•	•	•	•	—	•	•	•	•	•	—
20	•	•	•	•	•	—	•	•	•	•	•	—
24	•	•	•	•	—	—	•	•	•	•	—	—
30	•	•	•	—	—	—	•	•	•	—	—	—
36	•	•	•	—	—	—	•	•	•	—	—	—

# BALL VALVE STEM TORQUES

## Stem Break Torque at Maximum Operating Pressure (in-lbs)

**Example:** A 4" full port (67) or 6" reduced port (57) class 300 valve with G/PTFE seats has a stem torque of 2605 in-lbs at maximum allowable working pressure.

Bore Size (in.)	Pressure Class											
	150 285 PSI	300 740 PSI	600 1480 PSI	900 2220 PSI	1500 3705 PSI	2500 6170 PSI	150 285 PSI	300 740 PSI	600 1480 PSI	900 2220 PSI	1500 3705 PSI	2500 6170 PSI
	G/PTFE		DEVLON				PEEK					
2	774	1024	1431	1838	2665	2879	793	1050	1467	1884	2721	2950
3	1282	1678	2322	2966	4258	4598	1610	2108	2917	3725	5348	5775
4	1895	2605	3759	4914	6853	7230	2280	3134	4523	5912	8245	8699
6	4150	5424	7496	9568	14343	20922	5544	7246	10014	12782	19160	27949
8	5668	8234	12408	16581	28852	40237	6629	9631	14512	19393	33744	47060
10	8200	11972	18107	25788	47450	73003	10107	14757	22318	31785	58485	89980
12	15083	19974	27929	39918	63547	105651	18246	24162	33785	48287	76870	127801
14	19850	25474	34620	64734	90377	—	23113	29661	40310	75373	105231	—
16	25605	33891	47366	87374	132277	—	32118	42511	59414	109597	165921	—
18	27435	42254	66356	153200	238017	—	33376	51404	80725	186374	289556	—
20	42938	61365	91335	215004	340015	—	51089	73014	108673	255817	404558	—
24	55186	93701	156342	243847	—	—	65573	111337	185767	289742	—	—
30	97655	135420	315780	—	—	—	116035	160908	375213	—	—	—
36	150105	227015	436562	—	—	—	178357	269742	518727	—	—	—

- NOTES:**
- 1) Torque values are for new valves with clean water service. No additional safety factors have been added.
  - 2) For powered actuators, multiply values x 1.25
  - 3) For dirty service, multiply values x 1.3
  - 4) For dry gas service, multiply values x 1.25
  - 5) To prevent stem side loading and eliminate potential stem galling, we recommend the following tolerances for mounting actuators:
    - a) Actuator mounting bracket flanges must be parallel within .015"
    - b) The maximum allowed run out on the stem coupling bores is .008"

# FLOW COEFFICIENTS (Cv)

By definition, Cv is the volume of water in gallons per minute at 60°F that will flow through a given element with a pressure drop of 1 psi.

Size (in.)	57 Three-Piece						67 Three-Piece					
	Pressure Class						Pressure Class					
	150	300	600	900	1500	2500	150	300	600	900	1500	2500
2	—	—	—	—	—	—	500	460	400	330	330	300
3	180	195	180	187	187	150	1350	1150	1050	935	830	740
4	545	535	550	510	510	410	2500	2200	1850	1760	1660	1460
6	790	765	745	740	740	590	5300	5290	4460	4405	4100	2600
8	1945	1945	2220	2035	1930	1400	10500	9600	8730	8475	8010	5370
10	4050	4040	4065	4050	3860	3050	17500	16750	14250	14205	13310	8630
12	6900	7100	7050	7025	6670	5350	26300	25500	22550	21430	17070	12500
14	13100	13200	13350	13300	12630	—	31850	30050	28400	26800	24275	—
16	14600	14580	14300	14200	13490	—	43300	41700	38150	36700	33215	—
18	19750	19800	20350	19750	18760	—	57300	55370	50950	48700	43400	—
20	27750	28050	28300	27300	20470	—	74500	72300	65600	62500	55930	—
24	27100	27130	27250	26900	—	—	112300	109150	98150	94050	—	—
30	39700	39800	40750	—	—	—	161700	155650	143200	—	—	—
36	63100	63100	68950	—	—	—	233600	219450	199800	—	—	—

## PRESSURE/TEMPERATURE

The chart below depicts pressure and temperature ratings for common plastics and elastomers used in PBV ball valves. Other materials are available upon request.

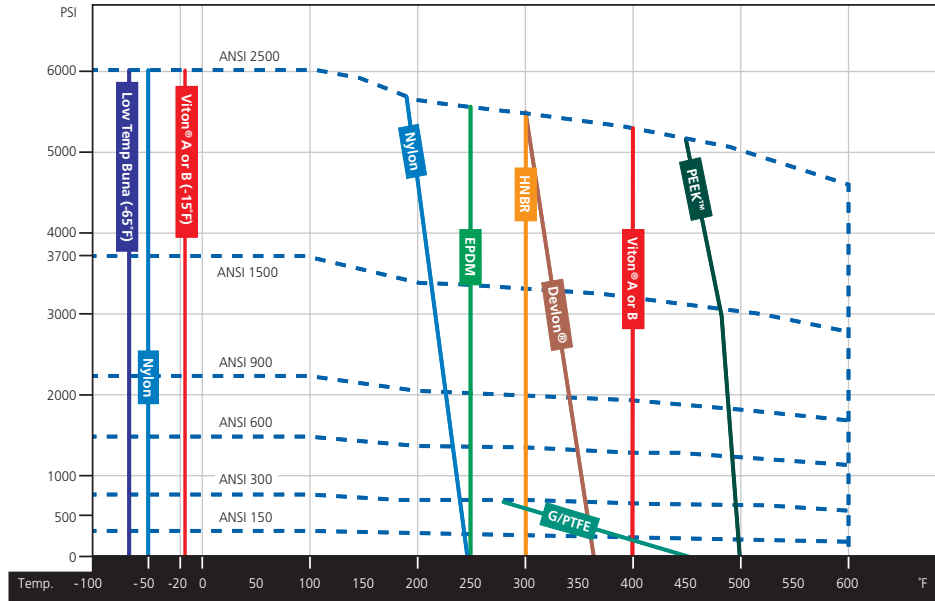

## BLOCK AND BLEED DEFINED

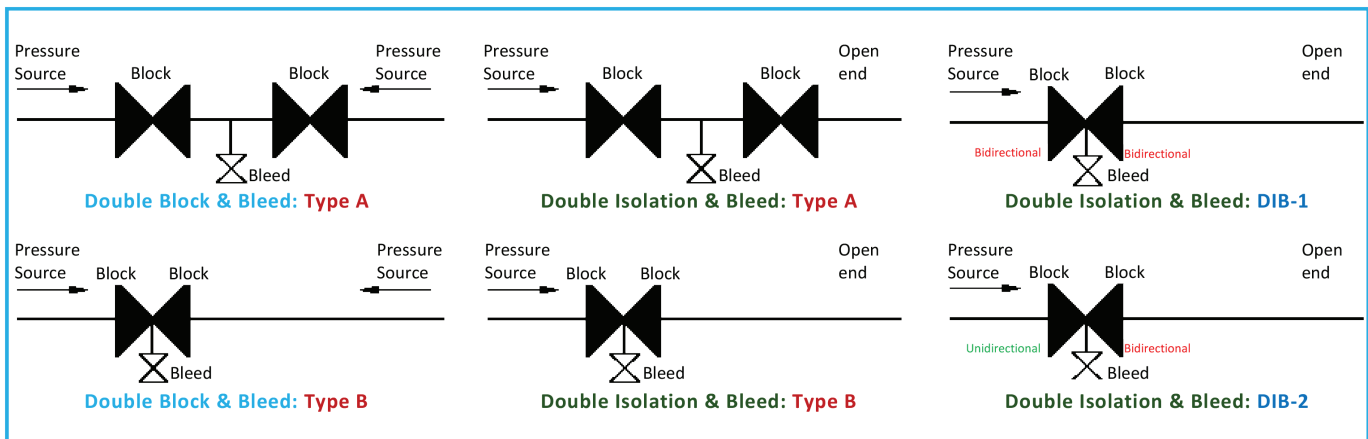

According to API 6D.

Double Block and Bleed Valve is a "single valve with two seating surfaces that, in the closed position, provides a seal against pressure from both ends of the valve with the means of venting/bleeding the cavity between the seating surfaces."

NOTE: This valve does not provide positive double isolation when only one side is under pressure.

Double Isolation and Bleed Valve is a "single valve with two seating surfaces, each of which, in the closed position, provides a seal against pressure from a single source, with the means of venting/bleeding the cavity between the seating surfaces."

NOTE: This feature can be provided in one or both directions.

Double Isolation and Bleed DIB-1, Both seats bidirectional

Double Isolation and Bleed DIB-2, One seat unidirectional and one seat bidirectional



## MODIFICATIONS, SERVICES, AND REPAIR KITS

PBV offers custom-engineered modifications and services, either in-house or specified by the customer.

### Automation

PBV provides complete automated valve packages with various options for instrumentation and controls.

The Topworks design is compatible with pneumatic, electric, hydraulic, or gas-over-oil actuators. By minimizing breakaway and run torque, PBV ensures economical actuator packages. Actuated ball valves can be supplied directly from PBV under a single warranty, with valve/actuator assemblies tested to customer specifications before shipment.

### Coatings

- External epoxy coating
- Holiday free
- Internal coating

### Stem Extensions

- Modification options are available for high-head or gear-mount extensions for buried service.
- Applications with fully extended lube lines.
- Lube lines provided in either welded or threaded lube fitting construction.

### Pup Extensions

Pup extensions and transition pieces are among the modifications we supply upon request.

### PBV Repair Kits

Spare parts are available for quick delivery. Providing valve serial numbers with orders ensures the correct parts are shipped. Contact your PBV salesperson for more information.

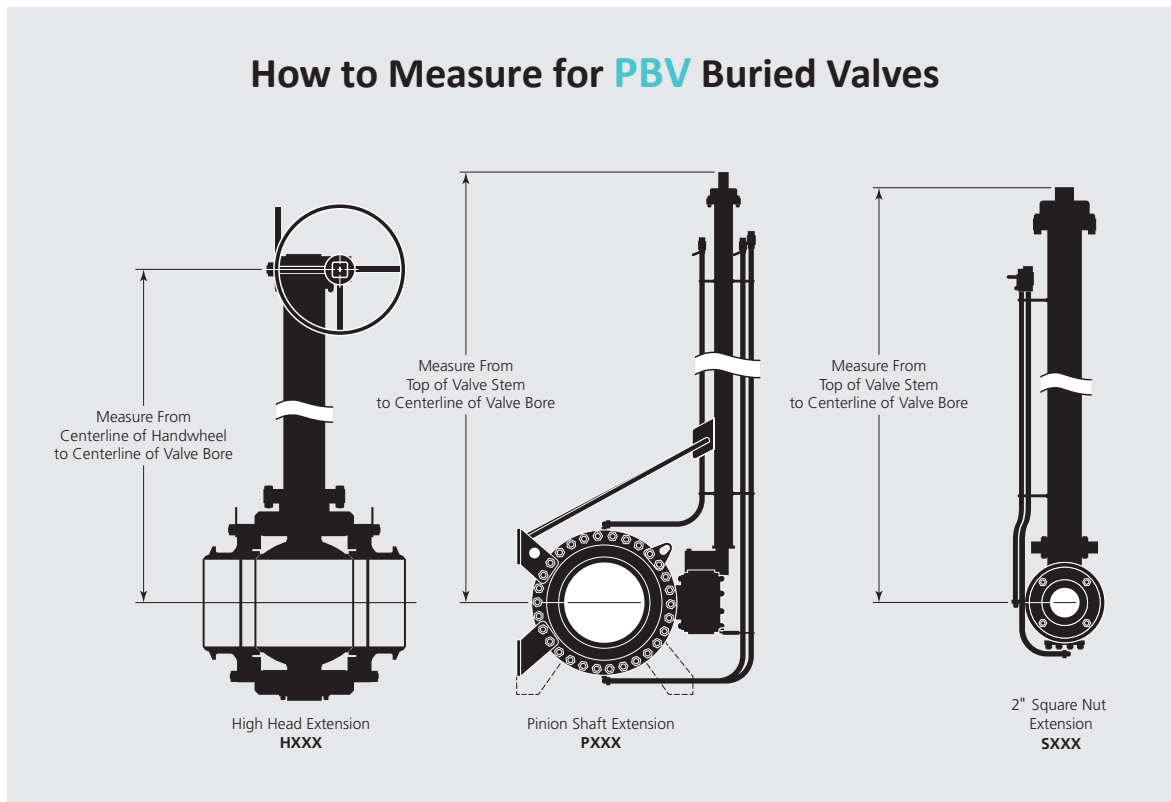

# PARTS & MATERIALS

## PBV 57/67 Three-Piece, 2" Full Port - 6" Reduced Port

No.	Description	Material	Spares
1	Body	A105/A350 LF2	
2	Closure/Flanged End	A105/A350 LF2	
4	Ball	316SS	
5	Stem	316SS	
6	Seat Ring Sub Assembly	316SS-G/PTFE 316SS-Nylon	S
9	Trunnion	4130 ENP	
10	Gland	4130 ENP	
12	Adapter Plate	A36	
20	Stem Key	Carbon Steel	
25	Stem Thrust Washer	Graphite	S
28	DU Bearing	DU Dry Bearing	
31	Seat/Stem Spring	X-750	
32	Body O-ring	HNBR	S
33	Seat O-ring	HNBR	S
34	Stem O-ring	HNBR	S
35	Gland & Trunnion O-ring	HNBR	S
39	Body Stud	A193 B7M	
40	Body Nut	A194 2HM	
43	Gland Cap Screw	A574 Modified	
44	Adapter Plate Cap Screw	A574 Modified	
45	Trunnion Cap Screw	A574 Modified	
46	Stem Key Cap Screw	Carbon Steel	
49	Stem Grease Fitting	Carbon Steel	
50	Body Grease Fitting	Carbon Steel	
51	Check Valve	Stainless Steel	
54	Drain Valve	Carbon Steel	
60	Handle/Lever	Carbon Steel	
62	Indicator Screw	Carbon Steel	
63	Retainer Washer	Carbon Steel	
64	Nameplate	Stainless Steel	
65	Drive Screw	Stainless Steel	
67	Handle Adapter	Carbon Steel	
69	Lock Screw	Carbon Steel	
70	Body Gasket	Graphite	S
71	Gland & Trunnion Gasket	Graphite	S
72	Stem Packing	Graphite	S

**NOTE:** Materials listed are typical for stainless steel trim valves. Stronger materials may be used to satisfy design requirements.

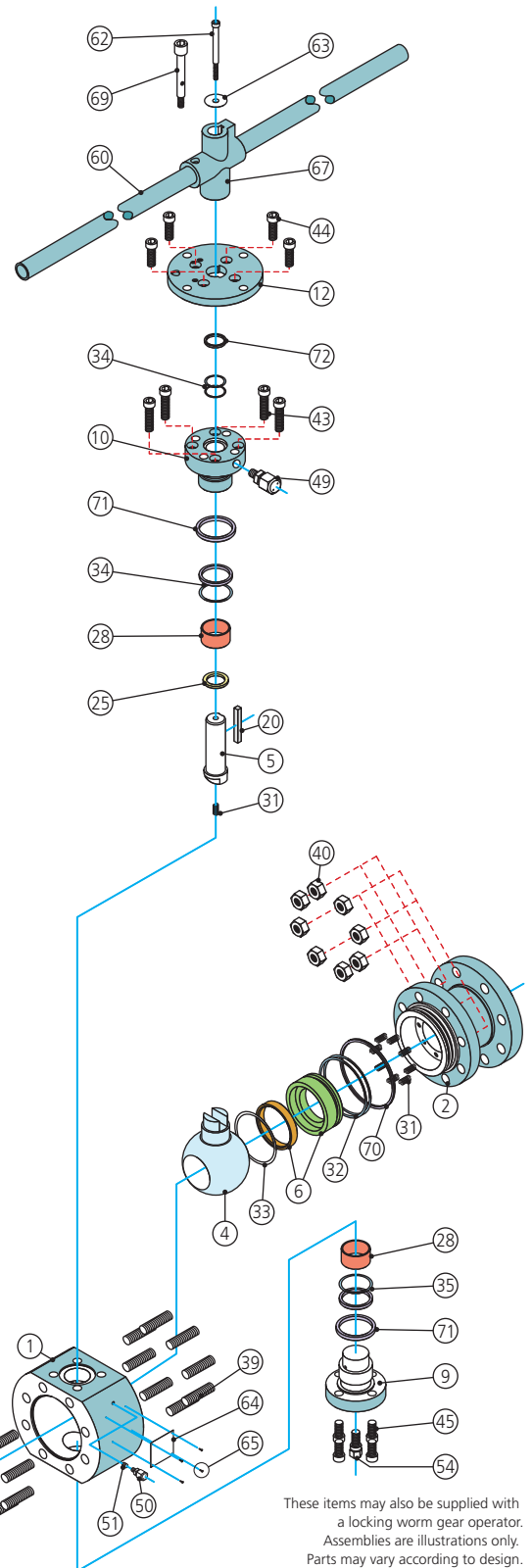

# DIMENSIONAL DATA

## PBV 57 Three-Piece, 3" - 6" Reduced Port

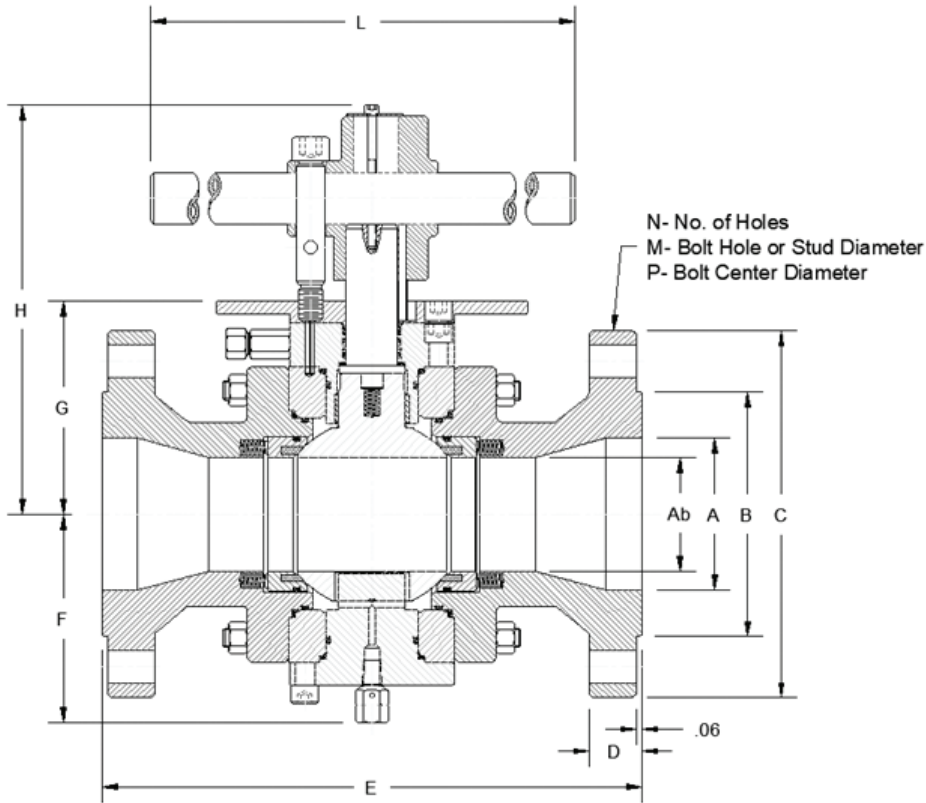

Dimensional Data, 57 Three-Piece

Size (in.)	Class	A	Ab	B	C	D	E1-RF	E2-RTJ	E3-WE	F	G	H	N	M	P	L
3	150	3.00	2.00	5.00	7.50	0.88	8.00	8.50	11.12	5.88	4.88	9.55	4	0.75	6.00	16
	300	3.00	2.00	5.00	8.25	1.06	11.12	11.75	11.12	4.88	4.88	9.55	8	0.88	6.62	18
	600	3.00	2.00	5.00	8.25	1.25	14.00	14.12	14.00	4.88	4.88	9.55	8	0.88	6.62	24
	900	3.00	2.00	5.00	9.50	1.50	15.00	15.12	15.00	4.88	4.88	9.55	8	1.00	7.50	30
	1500	3.00	2.00	5.00	10.50	1.88	18.50	18.62	18.50	5.32	5.47	10.30	8	1.25	8.00	30
	2500	2.50	1.75	5.00	12.00	2.62	22.75	23.00	22.75	6.38	7.25	13.19	8	1.38	9.00	30
4	150	4.00	3.00	6.19	9.00	0.88	9.00	9.50	12.00	7.30	5.94	10.92	8	0.75	7.50	18
	300	4.00	3.00	6.19	10.00	1.19	12.00	12.62	12.00	5.88	5.94	10.92	8	0.88	7.88	24
	600	4.00	3.00	6.19	10.75	1.50	17.00	17.12	17.00	5.88	5.94	10.92	8	1.00	8.50	30
	900	4.00	3.00	6.19	11.50	1.75	18.00	18.12	18.00	5.88	5.94	10.92	8	1.25	9.25	30
	1500	4.00	3.00	6.19	12.25	2.12	21.50	21.62	21.50	6.88	6.42	11.60	8	1.38	9.50	30
	2500	3.50	2.50	6.19	14.00	3.00	26.50	26.88	26.50	8.20	8.42	14.68	8	1.62	10.75	30
6	150	6.00	4.00	8.50	11.00	0.94	15.50	16.00	18.00	7.30	7.35	12.93	8	0.88	9.50	30
	300	6.00	4.00	8.50	12.50	1.38	15.88	16.50	18.00	7.30	7.35	12.93	12	0.88	10.62	30
	600	6.00	4.00	8.50	14.00	1.88	22.00	22.12	22.00	7.30	7.35	12.93	12	1.12	11.50	30
	900	6.00	4.00	8.50	15.00	2.19	24.00	24.12	24.00	7.30	7.35	12.93	12	1.25	12.50	48
	1500	5.75	4.00	8.50	15.50	3.25	27.75	28.00	27.75	8.14	7.88	13.75	12	1.50	12.50	48
	2500	5.25	3.50	8.50	19.00	4.25	36.00	36.50	36.00	9.44	10.56	16.93	8	2.12	14.50	48

## DIMENSIONAL DATA

### PBV 67 Three-Piece, 2" - 4" Full Port

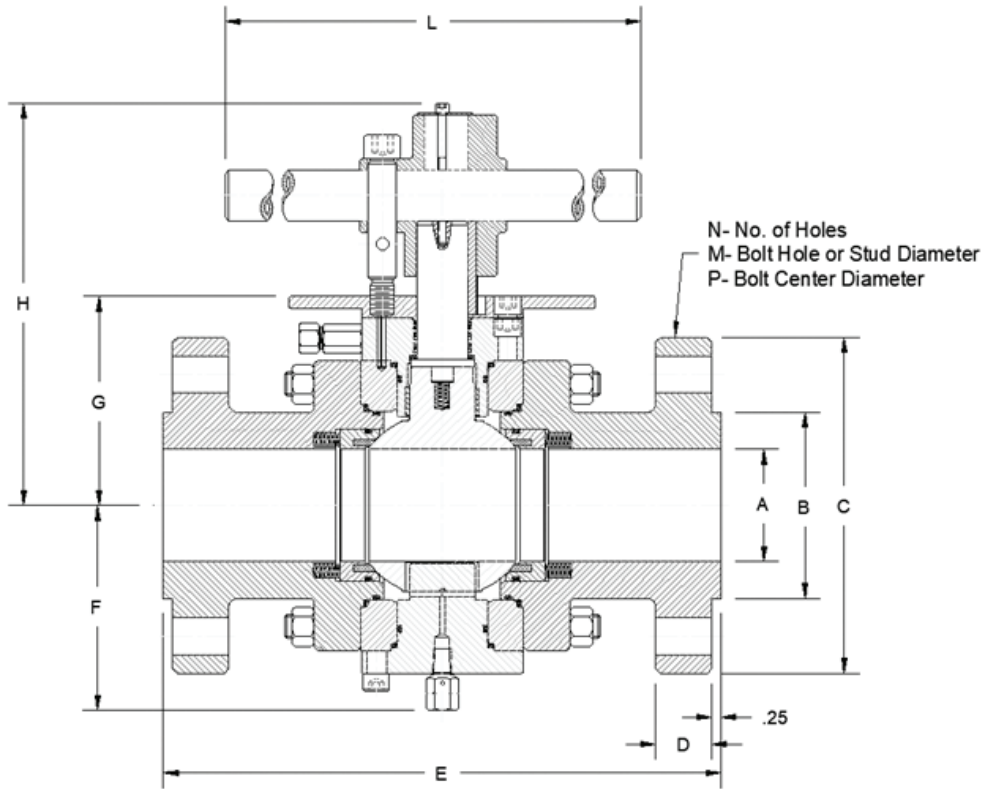

Dimensional Data, 67 Three-Piece

Size (in.)	Class	A	B	C	D	E1-RF	E2-RTJ	E3-WE	F	G	H	N	M	P	L
2	150	2.00	3.62	6.00	0.69	7.00	7.50	8.50	4.69	4.88	6.03	4	0.75	4.75	14.00
	300	2.00	3.62	6.50	0.81	8.50	9.12	8.50	4.69	4.88	6.03	8	0.75	5.00	16.00
	600	2.00	3.62	6.50	1.00	11.50	11.62	11.50	4.57	4.88	9.57	8	0.75	5.00	18.00
	900	2.00	3.62	8.50	1.50	14.50	14.62	14.50	4.88	4.88	9.55	8	1.00	6.50	24.00
	1500	2.00	3.62	8.50	1.50	14.50	14.62	14.50	5.32	5.47	10.30	8	1.00	6.50	24.00
	2500	1.75	3.62	9.25	2.00	17.75	17.88	17.75	6.39	7.25	13.19	8	1.12	6.75	30.00
3	150	3.00	5.00	7.50	0.88	8.00	8.50	11.12	5.59	4.88	9.96	4	0.75	6.00	18.10
	300	3.00	5.00	8.25	1.06	11.12	11.75	11.12	5.59	4.88	10.20	8	0.88	6.62	24.00
	600	3.00	5.00	8.25	1.25	14.00	14.12	14.00	5.5	4.88	10.92	8	0.88	6.62	30.00
	900	3.00	5.00	9.50	1.50	15.00	15.12	15.00	5.87	5.94	10.92	8	1.00	7.50	30.00
	1500	3.00	5.00	10.50	1.88	18.50	18.62	18.50	6.88	6.42	11.60	8	1.25	8.00	30.00
	2500	2.50	5.00	12.00	2.62	22.75	23.00	22.75	8.20	8.42	14.68	8	1.38	9.00	30.00
4	150	4.00	6.19	9.00	0.88	9.00	9.50	12.00	6.61	7.35	11.51	8	0.75	9.50	18.00
	300	4.00	6.19	10.00	1.19	12.00	12.62	12.00	6.61	7.35	11.48	8	0.88	7.88	24.00
	600	4.00	6.19	10.75	1.50	17.00	17.12	17.00	7.30	7.35	12.93	8	1.00	8.50	24.00
	900	4.00	6.19	11.50	1.75	18.00	18.12	18.00	7.30	7.35	12.93	8	1.25	9.25	30.00
	1500	4.00	6.19	12.25	2.12	21.50	21.62	21.50	8.14	7.88	13.75	8	1.38	9.50	30.00
	2500	3.50	6.19	14.00	3.00	26.50	26.88	26.50	9.43	10.56	16.93	8	1.62	10.75	48.00

# PARTS & MATERIALS

## PBV 57/67 Three-Piece, 6" Full Port - 14" Reduced Port

No.	Description	Material	Spares
1	Body	A105/A350 LF2	
2	Closure/Flanged End	A105/A350 LF2	
4	Ball	A105/A350 LF2 ENP	
5	Stem	4130 ENP	
6	Seat Ring Sub Assembly	A105/A350 LF2 ENP G/PTFE or Nylon	S
9	Trunnion	4130 ENP	
10	Gland	4130 ENP	
11	Bushing	Carbon Steel	
12	Adapter Plate	A36	
18	Gland Pin	Carbon Steel	
20	Stem Key	Carbon Steel	
25	Stem Thrust Washer	Graphite	S
28	DU Bearing	DU Dry Bearing	
31	Seat Spring	X-750	
32	Body O-ring	Viton	S
33	Seat O-ring	Viton	S
34	Stem O-ring	Viton	S
35	Gland & Trunnion O-ring	Viton	S
36	Emergency Sealant O-ring	Viton	S
39	Body Stud	A193 B7M	
40	Body Nut	A194 2HM	
43	Gland Cap Screw	A574 Modified	
44	Adapter Plate Cap Screw	A574 Modified	
45	Trunnion Cap Screw	A574 Modified	
46	Stem Key Cap Screw	Carbon Steel	
47	Gear Stud	A193 B7	
48	Gear/Adapter Plate Nut	A194 2H	
49	Stem Grease Fitting	Carbon Steel	
50	Seat Grease Fitting	Carbon Steel	
51	Check Valve	Stainless Steel	
52	Vent Plug	Carbon Steel	
53	Lifting Lug Stud	A193 B7M	
54	Drain Valve	Carbon Steel	
55	Lifting Lug	Carbon Steel	
57	Worm Gear Operator	Commercial	
60	Handwheel	Carbon Steel	
64	Nameplate	Stainless Steel	
65	Drive Screw	Stainless Steel	
70	Body Gasket	Graphite	S
71	Gland & Trunnion Gasket	Graphite	S
72	Stem Packing	Graphite	S

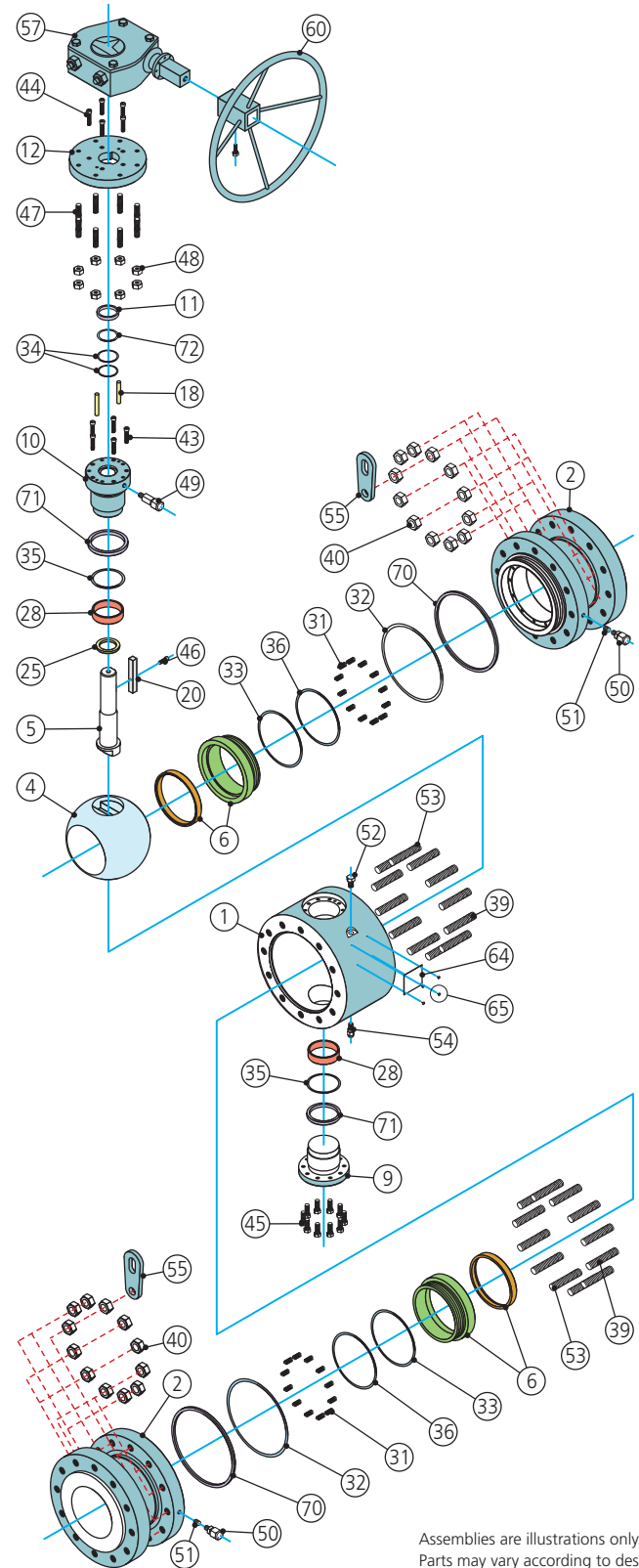

**NOTE:** Sizes 6" and 8" may be supplied with locking levers. Sizes 10" and 12" are supplied with support feet, not shown. Materials listed are typical for carbon steel valves. Ball, stem & seat rings will be 316, 17-4PH, or XM-19 for stainless steel trim depending on design requirements.

Assemblies are illustrations only.  
Parts may vary according to design.

# DIMENSIONAL DATA

## PBV 57 Three-Piece, 8" - 14" Reduced Port

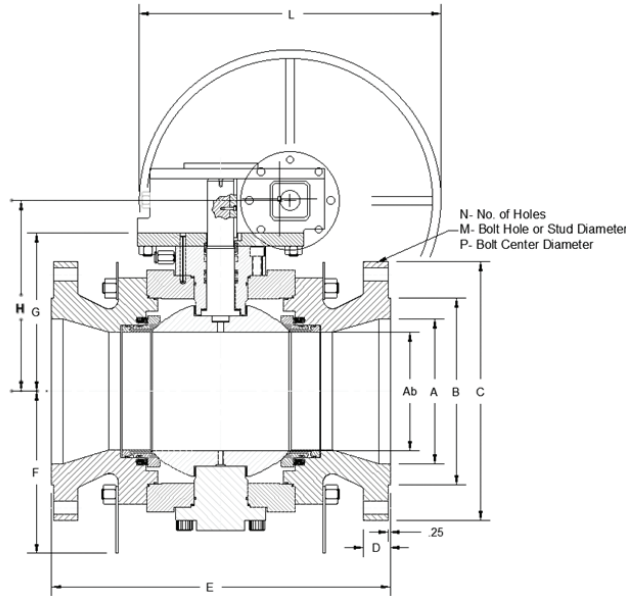

Dimensional Data, 57 Three-Piece

Size (in.)	Class	A	Ab	B	C	D	E1-RF	E2-RTJ	E3-WE	F	G	H	N	M	P	L
8	150	8.00	6.00	10.62	13.50	1.06	18.00	18.50	20.50	7.25	8.48	10.63	8	0.88	11.75	24
	300	8.00	6.00	10.62	15.00	1.56	19.75	20.38	20.50	7.25	8.48	10.63	12	1.00	13.00	24
	600	8.00	6.00	10.62	16.50	2.19	26.00	26.12	26.00	7.25	8.48	10.63	12	1.25	13.75	24
	900	8.00	6.00	10.62	18.50	2.50	29.00	29.12	29.00	8.62	10.01	12.14	12	1.50	15.50	24
	1500	7.62	5.75	10.62	19.00	3.62	32.75	33.12	32.75	9.75	10.67	12.80	12	1.75	15.50	24
	2500	7.12	5.25	10.62	21.75	5.00	40.25	40.88	40.25	12.74	12.70	19.28	12	2.12	17.25	30
10	150	10.00	8.00	12.75	16.00	1.12	21.00	21.50	22.00	8.72	10.13	12.26	12	1.00	14.25	24
	300	10.00	8.00	12.75	17.50	1.81	22.38	23.00	22.00	8.72	10.13	12.26	16	1.12	15.25	24
	600	10.00	8.00	12.75	20.00	2.50	31.00	31.12	31.00	11.25	11.57	13.70	16	1.38	17.00	24
	900	10.00	8.00	12.75	21.50	2.75	33.00	33.12	33.00	10.00	11.57	13.70	16	1.50	18.50	24
	1500	9.50	7.62	12.75	23.00	4.25	39.00	39.38	39.00	12.16	12.88	19.46	12	2.00	19.00	30
	2500	8.88	7.12	12.75	26.50	6.50	50.00	50.88	50.00	15.22	16.63	18.76	12	2.62	21.25	30
12	150	12.00	10.00	15.00	19.00	1.19	24.00	24.50	25.00	10.56	11.96	14.09	12	1.00	17.00	24
	300	12.00	10.00	15.00	20.50	1.94	25.50	26.12	25.00	10.56	11.96	14.09	16	1.25	17.75	24
	600	12.00	10.00	15.00	22.00	2.62	33.00	33.12	33.00	12.76	13.32	15.45	20	1.38	19.25	24
	900	12.00	10.00	15.00	24.00	3.12	38.00	38.12	38.00	11.74	13.32	19.90	20	1.50	21.00	30
	1500	11.38	9.50	15.00	26.50	4.88	44.50	45.12	44.50	14.40	15.48	22.06	16	2.12	22.50	30
	2500	10.50	8.88	15.00	30.00	7.25	56.00	56.88	56.00	19.73	18.25	24.83	12	2.88	24.38	30
14	150	13.25	12.00	16.25	21.00	1.31	27.00	27.50	30.00	12.26	13.75	15.88	12	1.12	18.75	24
	300	13.25	12.00	16.25	23.00	2.06	30.00	30.62	30.00	12.26	13.75	15.88	20	1.25	20.25	30
	600	13.25	12.00	16.25	23.75	2.75	35.00	35.12	35.00	13.86	14.94	21.52	20	1.50	20.75	30
	900	12.75	12.00	16.25	22.25	3.38	40.50	40.88	40.50	13.86	15.46	21.52	20	1.62	22.00	30
	1500	12.50	11.38	16.25	29.50	5.25	49.50	50.25	49.50	16.98	17.83	24.41	16	2.38	25.00	30

# DIMENSIONAL DATA

## PBV 67 Three-Piece, 6" - 12" Full Port

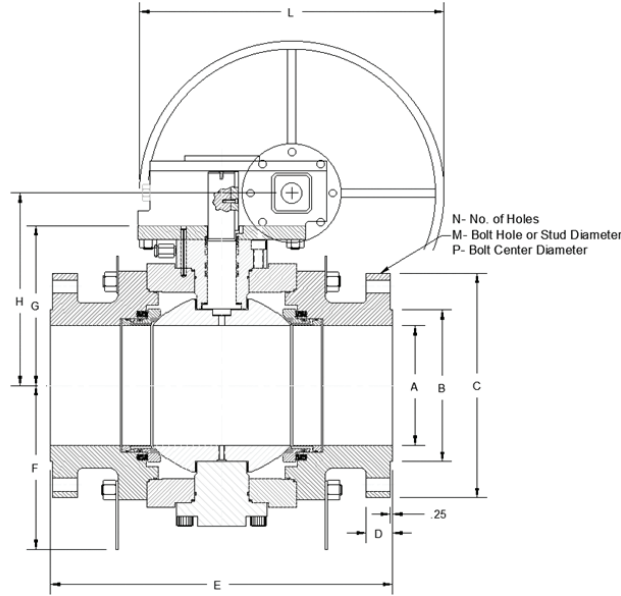

Dimensional Data, 67 Three-Piece

Size (in.)	Class	A	B	C	D	E1-RF	E2-RTJ	E3-WE	F	G	H	N	M	P	L
6	150	6.00	8.50	11.00	0.94	15.50	16.00	18.00	7.25	8.48	10.63	8	0.88	9.50	24
	300	6.00	8.50	12.50	1.38	15.88	16.50	18.00	7.25	8.48	10.63	12	0.88	10.62	24
	600	6.00	8.50	14.00	1.88	22.00	22.12	22.00	7.25	8.48	10.63	12	1.12	11.50	24
	900	6.00	8.50	15.00	2.19	24.00	24.12	24.00	8.62	10.01	12.14	12	1.25	12.50	24
	1500	5.75	8.50	15.50	3.25	27.75	28.00	27.75	9.72	10.67	12.80	12	1.50	12.50	24
	2500	5.25	8.50	19.00	4.25	36.00	36.50	36.00	12.74	12.70	19.28	8	2.12	14.50	30
8	150	8.00	10.62	13.50	1.06	18.00	18.50	20.50	8.72	10.13	12.26	8	0.88	11.75	24
	300	8.00	10.62	15.00	1.56	19.75	20.38	20.50	8.72	10.13	12.26	12	1.00	13.00	24
	600	8.00	10.62	16.50	2.19	26.00	26.12	26.00	11.25	11.57	13.70	12	1.25	13.75	24
	900	8.00	10.62	18.50	2.50	29.00	29.12	29.00	10.00	11.57	13.70	12	1.50	15.50	24
	1500	7.62	10.62	19.00	3.62	32.75	33.12	32.75	12.16	12.88	19.46	12	1.75	15.50	30
	2500	7.12	10.62	21.75	5.00	40.25	40.88	40.25	15.22	16.63	18.76	12	2.12	17.25	30
10	150	10.00	12.75	16.00	1.12	21.00	21.50	22.00	10.56	11.96	14.09	12	1.00	14.25	24
	300	10.00	12.75	17.50	1.81	22.38	23.00	22.00	10.56	11.96	14.09	16	1.12	15.25	24
	600	10.00	12.75	20.00	2.50	31.00	31.12	31.00	12.76	13.32	15.45	16	1.38	17.00	24
	900	10.00	12.75	21.50	2.75	33.00	33.12	33.00	11.74	13.32	19.90	16	1.50	18.50	30
	1500	9.50	12.75	23.00	4.25	39.00	39.38	39.00	14.40	15.48	22.06	12	2.00	19.00	30
	2500	8.88	12.75	26.50	6.50	50.00	50.88	50.00	19.73	18.25	24.83	12	2.62	21.25	30
12	150	12.00	15.00	19.00	1.19	24.00	24.50	25.00	12.26	13.75	15.88	12	1.00	17.00	24
	300	12.00	15.00	20.50	1.94	25.50	26.12	25.00	12.26	13.75	15.88	16	1.25	17.75	24
	600	12.00	15.00	22.00	2.62	33.00	33.12	33.00	13.86	14.94	21.52	20	1.38	19.25	30
	900	12.00	15.00	24.00	3.12	38.00	38.12	38.00	13.86	15.46	21.52	20	1.50	21.00	30
	1500	11.38	15.00	26.50	4.88	44.50	45.12	44.50	16.98	17.83	24.41	16	2.12	22.50	30
	2500	10.50	15.00	30.00	7.25	56.00	56.88	56.00	22.06	20.79	27.69	12	2.88	24.38	30

# PARTS & MATERIALS

## PBV 57/67 Three-Piece, 14" - 36" Full Port

No.	Description	Material	Spares
1	Body	A105/A350 LF2	
2	Closure/Flanged End	A105/A350 LF2	
4	Ball	A105/A350 LF2 ENP	
5	Stem	4130 ENP	
6	Seat Ring Sub Assembly	A105/A350 LF2 ENP G/PTFE or Nylon	S
9	Bearing Retainer	Carbon Steel	
10	Gland	4130 ENP	
11	Bushing	Carbon Steel	
12	Adapter Plate	A36	
18	Gland Pin	Carbon Steel	
20	Stem Key	Carbon Steel	
22	Ball Thrust Washer	Phenolic	S
25	Stem Thrust Washer	Phenolic	S
28	DU Bearing	DU Dry Bearing	
31	Seat Spring	X-750	
32	Body O-ring	Viton	S
33	Seat O-ring	Viton	S
34	Stem O-ring	Viton	S
35	Gland O-ring	Viton	S
36	Emergency Sealant O-ring	Viton	S
38	Location Stud	A193 B7M	
39	Body Stud	A193 B7M	
40	Body Nut	A194 2HM	
43	Gland Cap Screw	A574 Modified	
44	Adapter Plate Cap Screw	A574 Modified	
46	Stem Key Cap Screw	Carbon Steel	
47	Gear Stud	A193 B7	
48	Gear/Adapter Plate Nut	A194 2H	
49	Stem Grease Fitting	Carbon Steel	
50	Seat Grease Fitting	Carbon Steel	
51	Check Valve	Stainless Steel	
52	Vent Plug	Carbon Steel	
53	Lifting Lug Stud	A193 B7M	
54	Drain Valve	Carbon Steel	
55	Lifting Lug	Carbon Steel	
56	Support Leg	Carbon Steel	
57	Worm Gear Operator	Commercial	
60	Handwheel	Carbon Steel	
64	Nameplate	Stainless Steel	
65	Drive Screw	Stainless Steel	
70	Body Gasket	Graphite	S
71	Gland & Trunnion Gasket	Graphite	S
72	Stem Packing	Graphite	S

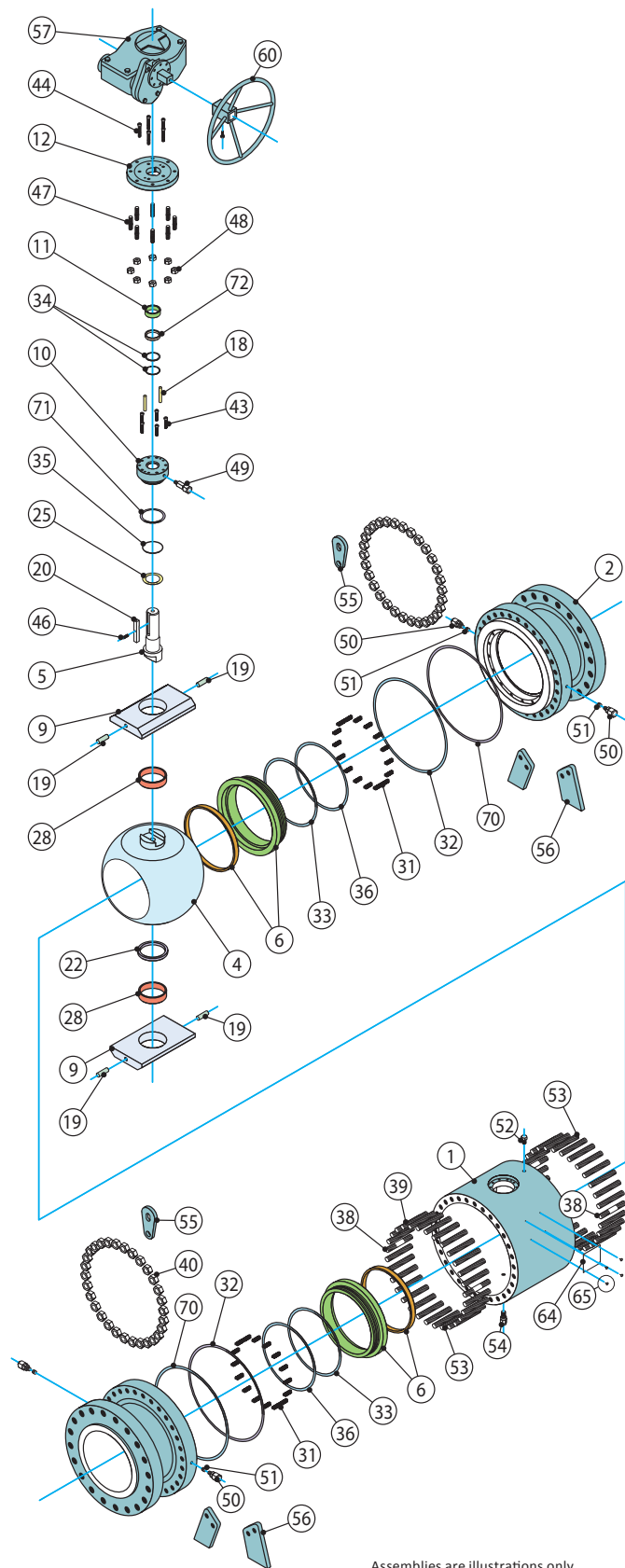

**NOTE:** Materials listed are typical for carbon steel valves. Ball, stem & seat rings will be 316, 17-4PH, or XM-19 or stainless steel trim depending on design requirements.

Assemblies are illustrations only. Parts may vary according to design.



# DIMENSIONAL DATA

## PBV 57 Three-Piece, 16" - 24" Reduced Port

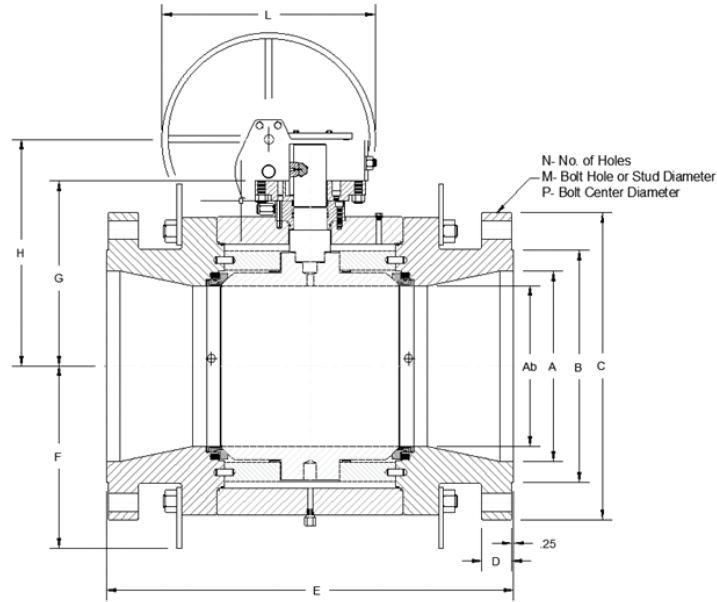

Dimensional Data, 57 Three-Piece

Size (in.)	Class	A	Ab	B	C	D	E1-RF	E2-RTJ	E3-WE	F	G	H	N	M	P	L
16	150	15.25	13.25	18.50	23.50	1.38	30.00	30.50	33.00	14.92	15.18	20.89	16	1.12	21.25	30
	300	15.25	13.25	18.50	25.50	2.19	33.00	33.62	33.00	14.92	14.31	20.89	20	1.38	22.50	30
	600	15.25	13.25	18.50	27.00	3.00	39.00	39.12	39.00	14.92	14.31	20.89	20	1.62	23.75	30
	900	14.75	12.75	18.50	27.75	3.50	44.50	44.88	44.50	18.61	16.76	23.34	20	1.75	24.25	30
	1500	14.25	12.50	18.50	32.50	5.75	54.50	55.38	54.50	20.60	18.83	25.73	16	2.62	27.75	30
18	150	17.25	15.25	21.00	25.00	1.50	34.00	34.50	36.00	16.60	15.88	22.47	16	1.25	22.75	30
	300	17.25	15.25	21.00	28.00	2.31	36.00	36.62	36.00	16.60	15.88	22.47	24	1.38	24.75	30
	600	17.25	15.25	21.00	29.25	3.25	43.00	43.12	43.00	16.33	15.88	22.47	20	1.75	25.75	30
	900	16.75	14.75	21.00	31.00	4.00	48.00	48.50	48.00	20.63	18.88	25.77	20	2.00	27.00	30
20	150	19.25	17.25	23.00	27.50	1.62	36.00	36.50	39.00	21.05	19.76	26.34	20	1.25	25.00	30
	300	19.25	17.25	23.00	30.50	2.44	39.00	39.75	39.00	21.05	19.76	26.34	24	1.38	27.00	30
	600	19.25	17.25	23.00	32.00	3.50	47.00	47.25	47.00	21.05	19.76	23.20	24	1.75	28.50	30
	900	18.62	16.75	23.00	33.75	4.25	52.00	52.50	52.00	23.39	24.91	31.81	20	2.12	29.50	30
24	150	23.25	19.25	27.25	32.00	1.81	42.00	42.50	45.00	22.75	20.20	26.78	20	1.38	29.50	30
	300	23.25	19.25	27.25	36.00	2.69	45.00	45.88	45.00	19.67	20.20	26.78	24	1.62	32.00	30
	600	23.25	19.25	27.25	37.00	4.00	55.00	55.38	55.00	19.67	20.09	23.53	24	2.00	33.00	30
	900	22.50	18.62	27.25	41.00	5.50	61.00	61.75	61.00	24.30	24.20	28.90	20	2.62	35.50	30

# DIMENSIONAL DATA

## PBV 67 Three-Piece, 14" - 36" Full Port

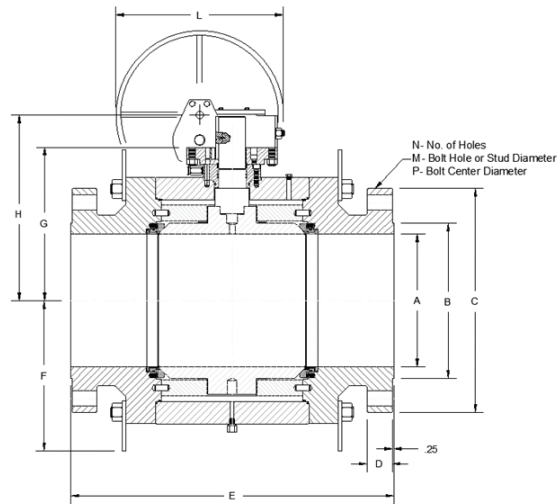

Dimensional Data, 67 Three-Piece

Size (in.)	Class	A	B	C	D	E1-RF	E2-RTJ	E3-WE	F	G	H	N	M	P	L
14	150	13.25	16.25	21.00	1.31	27.00	27.50	30.00	14.92	15.18	20.89	12	1.12	18.75	30
	300	13.25	16.25	23.00	2.06	30.00	30.62	30.00	14.92	14.31	20.89	20	1.25	20.25	30
	600	13.25	16.25	23.75	2.75	35.00	35.12	35.00	14.92	14.31	20.89	20	1.50	20.75	30
	900	12.75	16.25	25.25	3.38	40.50	40.88	40.50	18.61	16.76	23.34	20	1.62	22.00	30
	1500	12.50	16.25	29.50	5.25	49.50	50.25	49.50	20.60	18.83	25.73	16	2.38	25.00	30
16	150	15.25	18.50	23.50	1.38	30.00	30.50	33.00	16.60	15.88	22.47	16	1.12	21.25	30
	300	15.25	18.50	25.50	2.19	33.00	33.62	33.00	16.60	15.88	22.47	20	1.38	22.50	30
	600	15.25	18.50	27.00	3.00	39.00	39.12	39.00	16.33	15.88	22.47	20	1.62	23.75	30
	900	14.75	18.50	27.75	3.50	44.50	44.88	44.50	20.63	18.88	25.77	20	1.75	24.25	30
	1500	14.25	18.50	32.50	5.75	54.50	55.38	54.50	22.27	20.50	27.40	16	2.62	27.75	30
18	150	17.25	21.00	25.00	1.50	34.00	34.50	36.00	21.05	19.76	26.34	16	1.25	22.75	30
	300	17.25	21.00	28.00	2.31	36.00	36.62	36.00	21.05	19.76	26.34	24	1.38	24.75	30
	600	17.25	21.00	29.25	3.25	43.00	43.12	43.00	21.05	19.76	23.20	20	1.75	25.75	30
	900	16.75	21.00	31.00	4.00	48.00	48.50	48.00	23.39	24.91	31.81	20	2.00	27.00	30
	1500	16.00	21.00	36.00	6.38	60.50	61.38	60.50	23.39	24.91	31.81	16	2.88	30.50	30
20	150	19.25	23.00	27.50	1.62	36.00	36.50	39.00	19.67	20.20	26.78	20	1.25	25.00	30
	300	19.25	23.00	30.50	2.44	39.00	39.75	39.00	19.67	20.20	26.78	24	1.38	27.00	30
	600	19.25	23.00	32.00	3.50	47.00	47.25	47.00	19.67	20.09	23.53	24	1.75	28.50	30
	900	18.62	23.00	33.75	4.25	52.00	52.50	52.00	24.30	26.18	33.08	20	2.12	29.50	30
	1500	17.90	23.00	38.75	7.00	65.50	66.38	65.50	21.70	27.50	28.90	16	3.12	32.75	30
24	150	23.25	27.25	32.00	1.81	42.00	42.50	45.00	22.75	23.34	30.24	20	1.38	29.50	30
	300	23.25	27.25	36.00	2.69	45.00	45.88	45.00	22.75	23.34	30.24	24	1.62	32.00	30
	600	23.25	27.25	37.00	4.00	55.00	55.38	55.00	23.13	25.35	28.79	24	2.00	33.00	30
	900	22.50	27.25	41.00	5.50	61.00	61.75	61.00	28.00	27.92	30.90	20	2.62	35.50	30
30	150	29.00	33.75	38.75	2.88	51.00	*	55.00	31.25	32.08	38.98	28	1.38	36.00	30
	300	29.00	33.75	43.00	3.57	55.00	56.00	55.00	31.25	32.08	38.98	28	1.88	39.25	30
	600	29.00	33.75	44.50	4.50	65.00	65.50	65.00	31.25	32.08	38.98	28	2.12	40.25	30
36	150	34.50	40.25	46.00	3.50	60.00	*	68.00	34.39	35.83	42.73	32	1.62	42.75	30
	300	34.50	40.25	50.00	4.07	68.00	69.12	68.00	34.39	35.83	42.73	32	2.12	46.00	30
	600	34.50	40.25	51.75	4.88	82.00	82.64	82.00	34.39	35.83	42.73	28	2.62	47.00	30

\* Beyond scope of ASME B16.10

## SHIPPING INFORMATION

### Weight (lbs.)

Size (in.)	57 Three-Piece						67 Three-Piece					
	Pressure Class						Pressure Class					
	150	300	600	900	1500	2500	150	300	600	900	1500	2500
2	—	—	—	—	—	—	60	65	70	115	120	385
3	75	90	100	130	175	480	110	125	140	175	230	605
4	140	150	200	240	260	770	190	220	270	330	385	880
6	270	285	395	550	700	1430	425	460	515	860	1155	2100
8	505	575	675	1070	1400	2580	565	715	1140	1410	1935	5500
10	640	820	1420	1760	2135	6710	960	1175	1700	2355	3430	7400
12	1100	1390	1895	2530	3930	9350	1310	1740	2310	3545	5180	10500
14	1460	1970	2575	3740	5580	—	1870	2240	2505	4435	5300	—
16	2025	2480	3050	4650	6700	—	2520	3015	3505	6260	9120	—
18	2685	3225	3900	6450	9620	—	3300	3750	4550	8970	13020	—
20	3482	3995	5095	9150	13820	—	4465	5105	6100	11380	16500	—
24	4920	5730	7325	11850	—	—	6910	8000	10800	18960	27500	—

### Shipping Dimensions (in.)

Size (in.)	57 Three-Piece						67 Three-Piece					
	Pressure Class						Pressure Class					
	150	300	600	900	1500	2500	150	300	600	900	1500	2500
2	—	—	—	—	—	—	7x8x14	9x7x14	12x7x14	15x11x16	15x10x17	18x11x18
3	8x10x14	11x9x14	14x9x14	15x12x16	19x13x17	23x14x18	8x10x17	11x9x16	14x9x17	15x12x16	19x13x18	23x14x20
4	9x12x17	12x11x16	17x12x17	18x15x16	22x15x18	27x17x20	9x12x19	12x11x19	17x12x19	18x15x22	22x15x20	27x17x20
6	16x14x19	16x14x19	22x15x19	24x20x22	27x19x20	37x23x20	16x14x19	16x14x20	22x15x19	24x20x25	28x19x25	37x23x28
8	18x18x19	20x17x20	26x18x19	29x24x25	33x23x25	41x26x28	18x18x22	20x17x22	26x18x25	29x24x30	33x23x30	41x26x36
10	21x21x22	22x19x22	31x22x25	33x28x30	39x28x30	51x32x36	21x21x26	22x19x25	31x22x28	33x28x33	39x28x33	51x32x42
12	24x25x26	26x23x25	33x24x28	38x31x33	45x32x33	57x26x42	27x25x29	26x23x29	33x24x34	38x31x36	45x32x36	57x36x46
14	27x23x29	30x25x29	35x26x34	41x33x36	50x35x36	—	27x23x35	30x25x35	35x26x36	41x33x38	50x35x38	—
16	30x26x35	33x28x35	39x30x36	45x36x38	55x39x38	—	34x28x39	33x28x39	39x30x40	45x36x41	55x39x41	—
18	34x28x39	36x31x39	43x32x40	49x40x41	61x43x41	—	34x28x43	36x31x43	43x32x44	49x40x41	61x43x44	—
20	36x30x43	39x34x43	47x35x44	43x44x44	66x47x44	—	36x30x47	39x34x47	47x35x47	53x44x51	66x47x51	—
24	42x35x47	45x40x47	55x41x47	62x53x51	—	—	42x35x58	45x40x58	55x41x58	62x53x55	—	—

Contact your PBV salesperson for additional weights / sizes larger than 24".

**NOTES:** 1) Weights and dimensions given for flanged end valves only.

2) Valves sizes 2" x 2" through 6" x 4" in all Classes are with Lever Operators. Valves sizes 6" x 6" and larger in all Classes are with Gear Operators.

3) Shipping dimensions do not include Lever or Handwheel for Gear Operator.

4) The above weights and dimensions are made available for the purpose of estimating shipping expenses. These numbers are near approximations for the valve only exclusive of crating or palletizing.



## OUR CORE VALUES

### No One Gets Hurt

The safety of our employees and customers is our first priority coupled with a healthy respect for the environment.

### Integrity

In everything we do, in every interaction, both internally and externally, we strive to operate with the utmost integrity and mutual respect.

### Customer Focused

Our products enhance our customer's performance and we listen to their needs and work with them to solve their challenges.

### Good Place To Work

We are committed to creating a workplace that fosters innovation, teamwork and pride. Every team member is integral to our success and is treated equally and fairly.

---

### FORUM ENERGY TECHNOLOGIES

 12735 Dairy Ashford Road  
Stafford, TX 77477

 +1 281 637 2000 (General)  
+1 281 637 2097 (Sales)

 [f-e-t.com/valve-solutions](http://f-e-t.com/valve-solutions)

 [ForumVS.Sales@f-e-t.com](mailto:ForumVS.Sales@f-e-t.com)

The information provided in this brochure is intended for informational purposes only. While we strive to maintain accuracy, please know that the content may change without notification. We do not guarantee the information's completeness, timeliness, or reliability. Any reliance on the content is at your discretion, and we assume no responsibility for errors, omissions, or inaccuracies that may occur.

Teflon is a registered trademark of Chemours. DEVLON is a trademark of Devol Engineering Limited. PEEK is a trademark of Victrex USA, Inc. Viton is a registered trademark of DuPont Dow Elastomers, LLC.

© 2025 FORUM ENERGY TECHNOLOGIES, INC. All rights reserved. PBV is a registered trademark of Forum US, Inc.